

SECTION **BR**
BRAKE SYSTEM

A
B
C
D
E

CONTENTS

<p>PRECAUTION 3</p> <p>PRECAUTIONS 3</p> <p style="padding-left: 20px;">Precaution for Supplemental Restraint System (SRS) "AIR BAG" and "SEAT BELT PRE-TENSIONER"3</p> <p style="padding-left: 20px;">Precautions Necessary for Steering Wheel Rotation after Battery Disconnect (Early Production, With Electronic Steering Column Lock)3</p> <p style="padding-left: 20px;">Precaution for Procedure without Cowl Top Cover.....4</p> <p style="padding-left: 20px;">Precaution for Brake System4</p> <p>PREPARATION 5</p> <p>PREPARATION 5</p> <p style="padding-left: 20px;">Special Service Tool5</p> <p style="padding-left: 20px;">Commercial Service Tool5</p> <p>SYMPTOM DIAGNOSIS 6</p> <p>NOISE, VIBRATION AND HARSHNESS (NVH) TROUBLESHOOTING 6</p> <p style="padding-left: 20px;">NVH Troubleshooting Chart6</p> <p>BASIC INSPECTION 7</p> <p>FRONT DISC BRAKE 7</p> <p>BRAKE PAD7</p> <p style="padding-left: 20px;">BRAKE PAD : Inspection7</p> <p>DISC ROTOR7</p> <p style="padding-left: 20px;">DISC ROTOR : Inspection7</p> <p>REAR DISC BRAKE 8</p> <p>BRAKE PAD8</p> <p style="padding-left: 20px;">BRAKE PAD : Inspection8</p> <p>DISC ROTOR8</p> <p style="padding-left: 20px;">DISC ROTOR : Inspection8</p> <p>BRAKE BOOSTER 9</p>	<p style="padding-left: 20px;">Inspection 9</p> <p>VACUUM LINES10</p> <p style="padding-left: 20px;">Inspection10</p> <p>BRAKE MASTER CYLINDER11</p> <p style="padding-left: 20px;">Inspection11</p> <p>BRAKE TUBE AND HOSE12</p> <p style="padding-left: 20px;">Hydraulic Circuit12</p> <p>FRONT BRAKE12</p> <p style="padding-left: 20px;">FRONT BRAKE : Inspection12</p> <p>REAR BRAKE13</p> <p style="padding-left: 20px;">REAR BRAKE : Inspection13</p> <p>ON-VEHICLE MAINTENANCE14</p> <p>BRAKE PEDAL14</p> <p style="padding-left: 20px;">Inspection and Adjustment14</p> <p>BRAKE FLUID16</p> <p style="padding-left: 20px;">Inspection16</p> <p style="padding-left: 20px;">Drain and Refill16</p> <p style="padding-left: 20px;">Bleeding Brake System16</p> <p>ON-VEHICLE REPAIR18</p> <p>BRAKE PEDAL18</p> <p style="padding-left: 20px;">Exploded View18</p> <p style="padding-left: 20px;">Removal and Installation18</p> <p>BRAKE TUBE AND HOSE20</p> <p style="padding-left: 20px;">Hydraulic Circuit20</p> <p style="padding-left: 20px;">Removal and Installation of Front Brake Piping and Brake Hose20</p> <p style="padding-left: 20px;">Removal and Installation of Rear Brake Piping and Brake Hose21</p> <p style="padding-left: 20px;">Inspection After Installation22</p> <p>BRAKE MASTER CYLINDER24</p> <p style="padding-left: 20px;">Exploded View24</p>
--	---

BR

G
H
I
J
K
L
M
N
O
P

Removal and Installation	24	DISASSEMBLY AND ASSEMBLY	38
BRAKE BOOSTER	26	BRAKE MASTER CYLINDER	38
Exploded View	26	Disassembly and Assembly	38
Removal and Installation	26	FRONT DISC BRAKE	40
VACUUM LINES	28	Disassembly and Assembly	40
Exploded View	28	REAR DISC BRAKE	43
Removal and Installation	28	Disassembly and Assembly	43
FRONT DISC BRAKE	30	SERVICE DATA AND SPECIFICATIONS	
Exploded View of Brake Pads	30	(SDS)	46
Removal and Installation of Brake Pads	30	SERVICE DATA AND SPECIFICATIONS	
Brake Burnishing Procedure	31	(SDS)	46
Exploded View of Brake Caliper	32	General Specifications	46
Removal and Installation of Brake Caliper and Ro-		Brake Pedal	46
tor	32	Check Valve	47
REAR DISC BRAKE	34	Brake Booster	47
Exploded View of Brake Pads	34	Front Disc Brake	47
Removal and Installation of Brake Pads	34	Rear Disc Brake	47
Brake Burnishing Procedure	35		
Exploded View of Brake Caliper	36		
Removal and Installation of Brake Caliper and Ro-			
tor	36		

PRECAUTIONS

< PRECAUTION >

PRECAUTION

PRECAUTIONS

Precaution for Supplemental Restraint System (SRS) "AIR BAG" and "SEAT BELT PRE-TENSIONER"

INFOID:000000005462724

The Supplemental Restraint System such as "AIR BAG" and "SEAT BELT PRE-TENSIONER", used along with a front seat belt, helps to reduce the risk or severity of injury to the driver and front passenger for certain types of collision. This system includes seat belt switch inputs and dual stage front air bag modules. The SRS system uses the seat belt switches to determine the front air bag deployment, and may only deploy one front air bag, depending on the severity of a collision and whether the front occupants are belted or unbelted. Information necessary to service the system safely is included in the SR and SB section of this Service Manual.

WARNING:

- To avoid rendering the SRS inoperative, which could increase the risk of personal injury or death in the event of a collision which would result in air bag inflation, all maintenance must be performed by an authorized NISSAN/INFINITI dealer.
- Improper maintenance, including incorrect removal and installation of the SRS, can lead to personal injury caused by unintentional activation of the system. For removal of Spiral Cable and Air Bag Module, see the SR section.
- Do not use electrical test equipment on any circuit related to the SRS unless instructed to in this Service Manual. SRS wiring harnesses can be identified by yellow and/or orange harnesses or harness connectors.

PRECAUTIONS WHEN USING POWER TOOLS (AIR OR ELECTRIC) AND HAMMERS

WARNING:

- When working near the Airbag Diagnosis Sensor Unit or other Airbag System sensors with the Ignition ON or engine running, DO NOT use air or electric power tools or strike near the sensor(s) with a hammer. Heavy vibration could activate the sensor(s) and deploy the air bag(s), possibly causing serious injury.
- When using air or electric power tools or hammers, always switch the Ignition OFF, disconnect the battery, and wait at least 3 minutes before performing any service.

Precautions Necessary for Steering Wheel Rotation after Battery Disconnect (Early Production, With Electronic Steering Column Lock)

INFOID:000000005885910

NOTE:

- Before removing and installing any control units, first turn the push-button ignition switch to the LOCK position, then disconnect both battery cables.
- After finishing work, confirm that all control unit connectors are connected properly, then re-connect both battery cables.
- Always use CONSULT-III to perform self-diagnosis as a part of each function inspection after finishing work. If a DTC is detected, perform trouble diagnosis according to self-diagnosis results.

This vehicle is equipped with a push-button ignition switch and a steering lock unit.

If the battery is disconnected or discharged, the steering wheel will lock and cannot be turned.

If turning the steering wheel is required with the battery disconnected or discharged, follow the procedure below before starting the repair operation.

OPERATION PROCEDURE

1. Connect both battery cables.

NOTE:

Supply power using jumper cables if battery is discharged.

2. Carry the Intelligent Key or insert it to the key slot and turn the push-button ignition switch to ACC position. (At this time, the steering lock will be released.)
3. Disconnect both battery cables. The steering lock will remain released with both battery cables disconnected and the steering wheel can be turned.
4. Perform the necessary repair operation.

PRECAUTIONS

< PRECAUTION >

5. When the repair work is completed, re-connect both battery cables. With the brake pedal released, turn the push-button ignition switch from ACC position to ON position, then to LOCK position. (The steering wheel will lock when the push-button ignition switch is turned to LOCK position.)
6. Perform self-diagnosis check of all control units using CONSULT-III.

Precaution for Procedure without Cowl Top Cover

INFOID:000000005462726

When performing the procedure after removing cowl top cover, cover the lower end of windshield with urethane, etc.

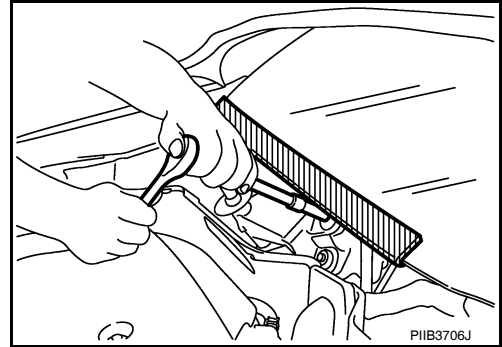

Precaution for Brake System

INFOID:000000005462727

- Clean dust on front brake and rear brake with a vacuum dust collector. Do not blow with compressed air.
- Always use recommended brake fluid. Refer to [MA-18. "FOR NORTH AMERICA : Fluids and Lubricants"](#) (for North America) or, [MA-19. "FOR MEXICO : Fluids and Lubricants"](#) (for Mexico).
- Never reuse drained brake fluid.
- Be careful not to splash brake fluid on painted areas; it may cause paint damage. If brake fluid is splashed on painted areas, wash it away with water immediately.
- Use clean brake fluid to clean or wash all parts of master cylinder and disc brake caliper, etc.
- Never use mineral oils such as gasoline or kerosene. They will ruin rubber parts of the hydraulic system.
- Use flare nut torque wrench when installing brake tube.
- When installing brake tube and hose, be sure to check torque.
- Before working, turn ignition switch OFF and disconnect connectors of ABS actuator and electric unit (control unit) or battery cable from the negative terminal.
- Burnish the brake contact surfaces after refinishing or replacing rotors, after replacing pads, or if a soft pedal occurs at very low mileage. Refer to [BR-31. "Brake Burnishing Procedure"](#).

WARNING:

- **Clean brake pads and shoes with a waste cloth, then wipe with a dust collector.**

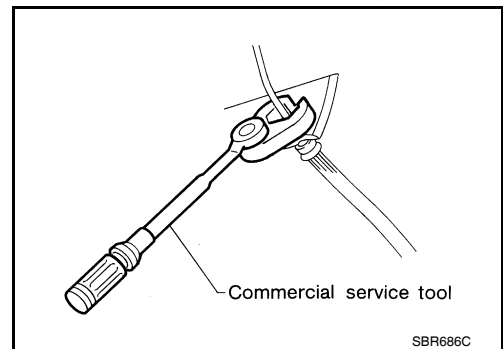

PREPARATION

< PREPARATION >

PREPARATION

PREPARATION

Special Service Tool

INFOID:000000005462728

The actual shapes of Kent-Moore tools may differ from those of special service tools illustrated here.

Tool number (Kent-Moore No.) Tool name	Description
— (J-46532) Brake and clutch pedal height measurement tool	Measuring brake pedal height
38-PFM90.5 (—) Pro-Cut PFM90 On-Car Brake Lathe	Turning rotors

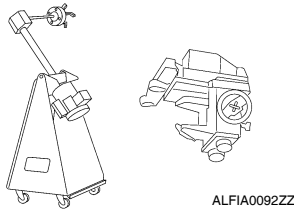
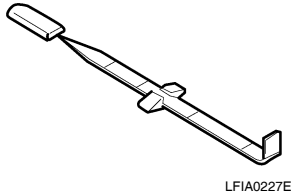

Commercial Service Tool

INFOID:000000005462729

Tool name	Description
1. Flare nut crowfoot 2. Torque wrench	Installing each brake tube and hose a: 10 mm (0.39 in) / 12 mm (0.47 in)
Power tool	Removing front and rear caliper assembly, wheel and tire
Pin punch	Removing and installing reservoir tank pin Tip diameter: 4 mm (0.16 in)

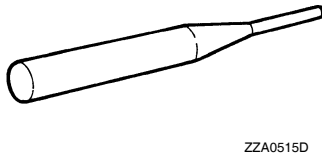
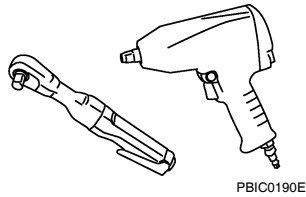
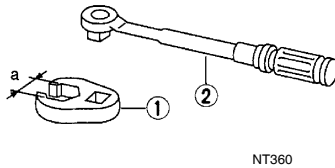

NOISE, VIBRATION AND HARSHNESS (NVH) TROUBLESHOOTING

< SYMPTOM DIAGNOSIS >

SYMPTOM DIAGNOSIS

NOISE, VIBRATION AND HARSHNESS (NVH) TROUBLESHOOTING

NVH Troubleshooting Chart

INFOID:000000005462730

Use the chart below to help you find the cause of the symptom. If necessary, repair or replace these parts.

Reference page		Possible cause and SUSPECTED PARTS															
		BR-7, BR-8	BR-7, BR-8	BR-7, BR-8	—	—	BR-7, BR-8	—	—	—	BR-7, BR-8	FAX-2, RAX-2	FSU-2	WT-57, "NVH Troubleshooting Chart"	WT-57, "NVH Troubleshooting Chart"	FAX-2, "NVH Troubleshooting Chart"	ST-8, "NVH Troubleshooting Chart"
		Pads - damaged	Pads - uneven wear	Shims damaged	Rotor imbalance	Rotor damage	Rotor runout	Rotor deformation	Rotor deflection	Rotor rust	Rotor thickness variation	WHEEL HUB	SUSPENSION	TIRES	ROAD WHEEL	DRIVE SHAFT	STEERING
Symptom	Noise	x	x	x								x	x	x	x	x	x
	Shake				x							x	x	x	x	x	x
	Shimmy, Shudder				x	x	x	x	x	x	x	x	x	x			x

x: Applicable

FRONT DISC BRAKE

< BASIC INSPECTION >

BASIC INSPECTION

FRONT DISC BRAKE

BRAKE PAD

BRAKE PAD : Inspection

INFOID:000000005462731

PAD WEAR

- Check pad thickness from the inspection hole on cylinder body. Check using a scale if necessary.

Standard thickness : Refer to [BR-47, "Front Disc Brake"](#).

Repair limit thickness : Refer to [BR-47, "Front Disc Brake"](#).

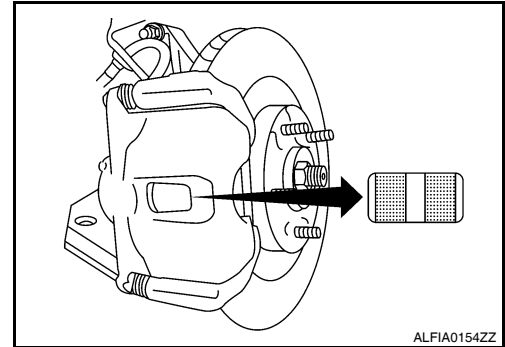

DISC ROTOR

DISC ROTOR : Inspection

INFOID:000000005462732

VISUAL

Check surface of disc rotor for uneven wear, cracks, and serious damage. Replace as necessary.

RUNOUT

1. Attach disc rotor to wheel hub using wheel nuts (at two or more positions).
2. Inspect runout using a dial gauge placed at 10 mm (0.39 in) inside the disc edge.

Runout limit : Refer to [BR-47, "Front Disc Brake"](#).
(with it attached to the vehicle)

NOTE:

Before measuring, make sure that wheel bearing axial end play is within the specification. Refer to [FAX-6, "Inspection"](#).

3. When runout exceeds limit value, displace mounting positions of disc rotor by one hole. Then find a position of the minimum value for runout.
4. If runout is outside the specified value after performing the above operation, turn disc rotor using Tool.

Tool number : 38-PFM90.5

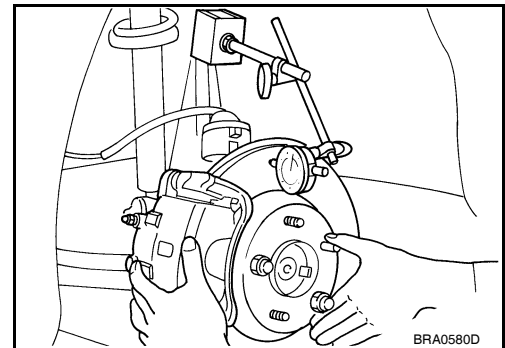

THICKNESS

Check thickness of the disc rotor using a micrometer. Replace disc rotor if thickness is under the wear limit.

Standard thickness : Refer to [BR-47, "Front Disc Brake"](#).

Repair limit thickness : Refer to [BR-47, "Front Disc Brake"](#).

Thickness variation (Measured at 8 positions) : Refer to [BR-47, "Front Disc Brake"](#).

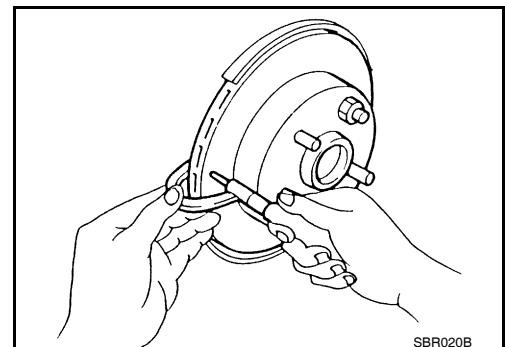

A
B
C
D
E
BR
G
H
I
J
K
L
M
N
O
P

REAR DISC BRAKE

< BASIC INSPECTION >

REAR DISC BRAKE

BRAKE PAD

BRAKE PAD : Inspection

INFOID:000000005462733

PAD WEAR

- Check pad thickness from the inspection hole on cylinder body. Check using a scale if necessary.

Standard thickness : Refer to [BR-47, "Rear Disc Brake"](#).

Repair limit thickness : Refer to [BR-47, "Rear Disc Brake"](#).

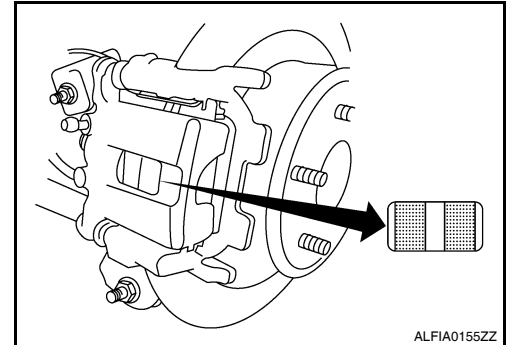

DISC ROTOR

DISC ROTOR : Inspection

INFOID:000000005462734

VISUAL

Check surface of disc rotor for uneven wear, cracks, and serious damage. Replace if necessary.

RUNOUT

1. Attach disc rotor to wheel hub using wheel nuts (at two or more positions).
2. Inspect runout using dial gauge placed at 10 mm (0.39 in) inside disc edge.

Runout limit : Refer to [BR-47, "Rear Disc Brake"](#).

(With it attached to the vehicle)

NOTE:

Before measuring, make sure that wheel bearing axial end play is within the specification. Refer to [FAX-6, "Inspection"](#).

3. When runout exceeds limit value, displace mounting positions of disc rotor by one hole. Then find a position of the minimum value for runout.
4. If runout is outside the specified value after performing the above operation, turn the disc rotor using Tool.

Tool number : 38-PFM90.5

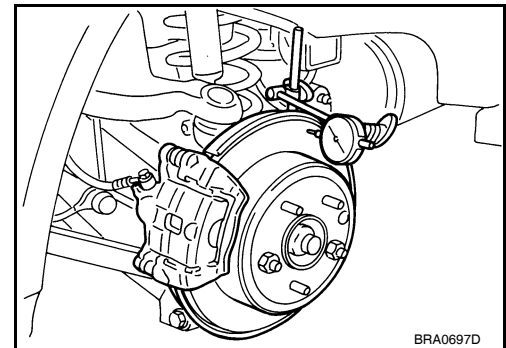

THICKNESS

Check the thickness of the disc rotor using a micrometer. Replace disc rotor if the thickness is less than the wear limit.

Standard thickness : Refer to [BR-47, "Rear Disc Brake"](#).

Repair limit thickness : Refer to [BR-47, "Rear Disc Brake"](#).

Thickness variation (Measured at 8 positions) : Refer to [BR-47, "Rear Disc Brake"](#).

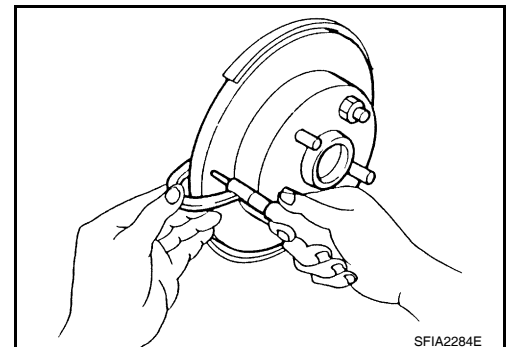

BRAKE BOOSTER

< BASIC INSPECTION >

BRAKE BOOSTER

Inspection

INFOID:000000005462735

OPERATION

With engine stopped, change vacuum to atmospheric pressure by depressing brake pedal several times. Then with brake pedal fully depressed, start engine and when vacuum pressure reaches the standard, make sure that clearance between brake pedal and floor panel decreases.

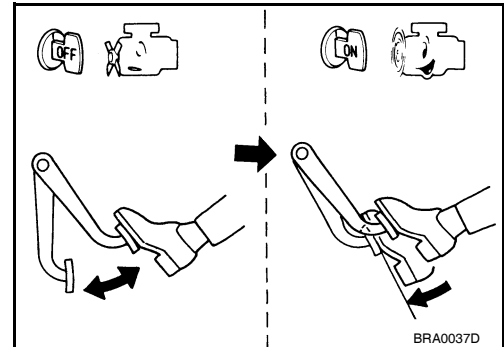

AIR TIGHT

- Run engine at idle for approximately 1 minute, and stop it after applying vacuum to booster. Depress brake pedal normally to change vacuum to atmospheric pressure. Make sure that distance at intervals of 5 seconds between brake pedal and floor panel gradually increases.

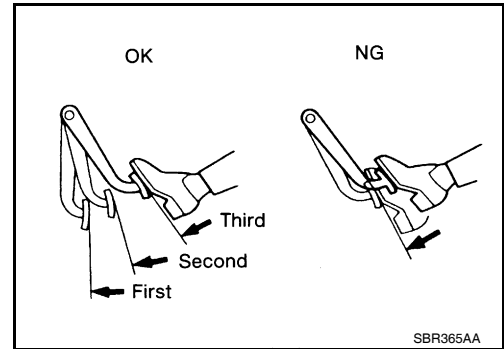

- Depress brake pedal while engine is running, and stop engine with pedal depressed. The pedal stroke should not change after holding pedal down for 30 seconds.

VACUUM LINES

< BASIC INSPECTION >

VACUUM LINES

Inspection

INFOID:000000005462736

VISUAL INSPECTION

Check for improper assembly, damage and deterioration. Replace as necessary.

CHECK VALVE INSPECTION

Airtightness Inspection

Use a suitable vacuum pump to check. Connect to brake booster side of check valve.

Check valve specification Refer to [BR-47, "Check Valve"](#).

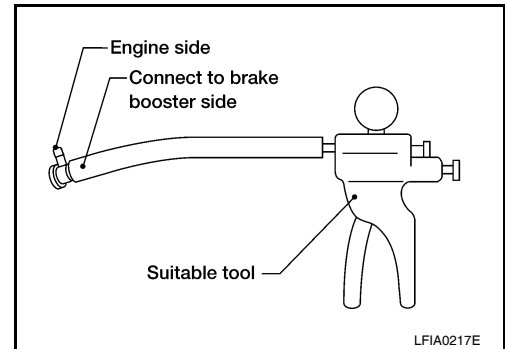

BRAKE MASTER CYLINDER

< BASIC INSPECTION >

BRAKE MASTER CYLINDER

Inspection

INFOID:000000005462737

LEAK INSPECTION

Check for leaks at master cylinder to brake booster attachment point, reservoir tank, and brake tube connections.

A

B

C

D

E

BR

G

H

I

J

K

L

M

N

O

P

BRAKE TUBE AND HOSE

< BASIC INSPECTION >

BRAKE TUBE AND HOSE

Hydraulic Circuit

INFOID:000000005462738

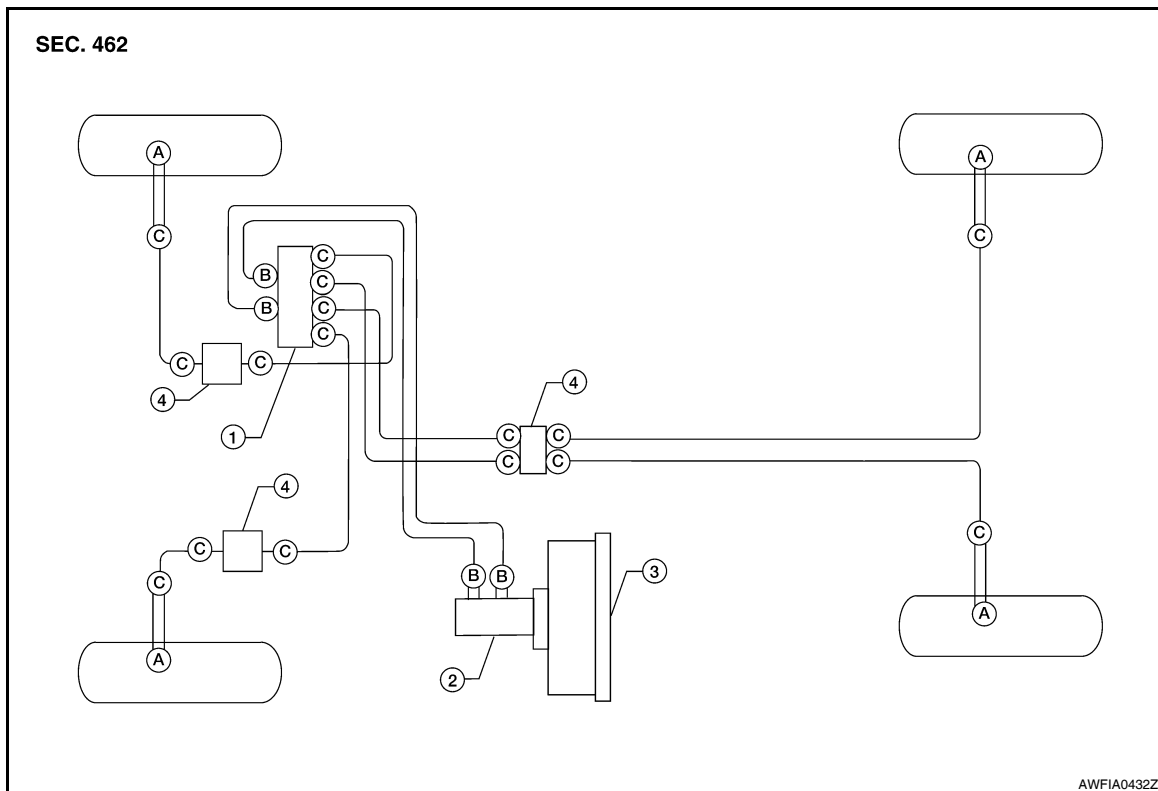

- | | | |
|---|--|---|
| 1. Actuator | 2. Master cylinder | 3. Brake booster |
| 4. Connector | A. Union bolt
18.2 N·m (1.9 kg-m, 13 ft-lb) | B. Flare nut M12
18.2 N·m (1.9 kg-m, 13 ft-lb) |
| C. Flare nut M10
16.2 N·m (1.7 kg-m, 12 ft-lb) | | |

CAUTION:

- All hoses and piping (tubes) must be free from excessive bending, twisting and pulling.
- Make sure there is no interference with other parts when turning the steering wheel both clockwise and counterclockwise.
- The brake piping is an important safety part. If a brake fluid leak is detected, always disassemble the parts. Replace applicable part with a new one, if necessary.
- Be careful not to splash brake fluid on painted areas; it may cause paint damage. If brake fluid is splashed on painted areas, wash it away with water immediately.
- Do not bend or twist brake hose sharply, or strongly pull it.
- When removing components, cover connections so that no dirt, dust, or other foreign matter gets in.
- Refill with new specified brake fluid. Refer to [MA-18, "FOR NORTH AMERICA : Fluids and Lubricants"](#) (for North America) or [MA-19, "FOR MEXICO : Fluids and Lubricants"](#) (for Mexico).
- Do not reuse drained brake fluid.

FRONT BRAKE

FRONT BRAKE : Inspection

INFOID:000000005462739

INSPECTION AFTER REMOVAL

CAUTION:

Brake tubes and hoses are important safety parts. Always disassemble the parts and retighten their fittings, if a brake fluid leak is detected. Replace applicable part with a new one, if damaged part is detected.

BRAKE TUBE AND HOSE

< BASIC INSPECTION >

1. Check brake lines (tubes and hoses) and connections for fluid leaks, damage, twists, deformation, contacts with other parts, and loose connections. Replace any parts as necessary. Refer to [BR-20, "Removal and Installation of Front Brake Piping and Brake Hose"](#).
2. While depressing brake pedal under a force of 785 N (80 kg-f, 177 lb-f) with engine running for approximately 5 seconds, check each part for fluid leaks.

REAR BRAKE

REAR BRAKE : Inspection

INFOID:000000005462740

INSPECTION AFTER REMOVAL

CAUTION:

Brake tubes and hoses are important safety parts. Always disassemble the parts and retighten their fittings, if a brake fluid leak is detected. Replace applicable part with a new one, if damaged part is detected.

1. Check brake lines (tubes and hoses) and connections for fluid leaks, damage, twists, deformation, contacts with other parts, and loose connections. Replace any parts as necessary. Refer to [BR-21, "Removal and Installation of Rear Brake Piping and Brake Hose"](#).
2. While depressing brake pedal under a force of 785 N (80 kg-f, 177 lb-f) with engine running for approximately 5 seconds, check each part for fluid leaks.

A
B
C
D
E
BR
G
H
I
J
K
L
M
N
O
P

BRAKE PEDAL

< ON-VEHICLE MAINTENANCE >

ON-VEHICLE MAINTENANCE

BRAKE PEDAL

Inspection and Adjustment

INFOID:000000005462741

INSPECTION

1. Inspect the brake pedal free height (H) from the floor using Tool at a 90° angle to the floor as shown.

Tool number : — (J-46532)

2. Adjust the brake pedal free height (H) to specifications.

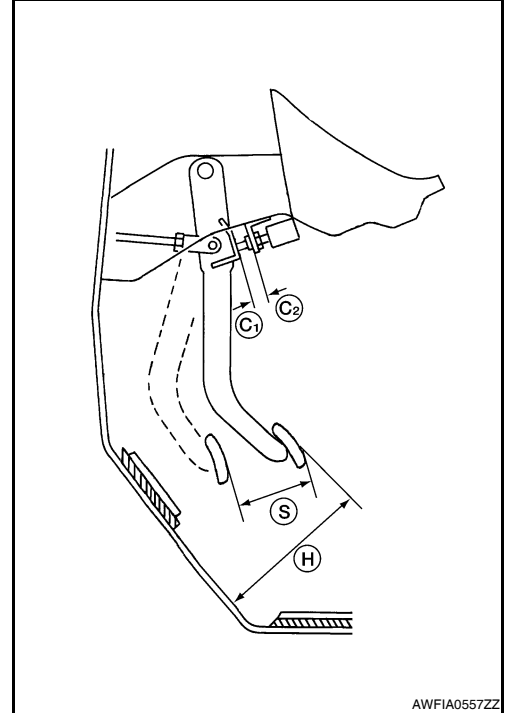

Brake pedal free height (H)	Refer to BR-46, "Brake Pedal" .
Brake pedal full stroke (S)	Refer to BR-46, "Brake Pedal" .
Clearance between brake pedal bracket and threaded end of stop lamp switch and ASCD cancel switch (C1) or (C2)	Refer to BR-46, "Brake Pedal" .

ADJUSTMENT

1. Loosen the stop lamp switch and ASCD cancel switch by turning 45° counterclockwise.

BRAKE PEDAL

< ON-VEHICLE MAINTENANCE >

- Loosen lock nut (A) on the input rod, then turn input rod to adjust the brake pedal to specified height. When finished adjusting, tighten lock nut (A) to specification.

Lock nut (A) : 18.7 N·m (1.9 kg-m, 14 ft-lb)

CAUTION:

Make sure that the screw portion of the end of input rod is located inside the clevis.

- With the brake pedal pulled up and held by hand, press the stop lamp switch and the ASCD cancel switch in until threaded ends contact the brake pedal bracket.
- With the threaded ends of the stop lamp switch and ASCD cancel switch contacting the pedal bracket, turn the switches 45° clockwise to lock in place. Check that the stop lamp switch and ASCD cancel switch threaded end to brake pedal bracket gap (C) is within specifications.

CAUTION:

Make sure that the gap (C) between the brake pedal bracket and stop lamp switch and ASCD cancel switch threaded ends are within specification.

- Check the brake pedal for smooth operation.

CAUTION:

Make sure that the stop lamp goes off when the brake pedal is released.

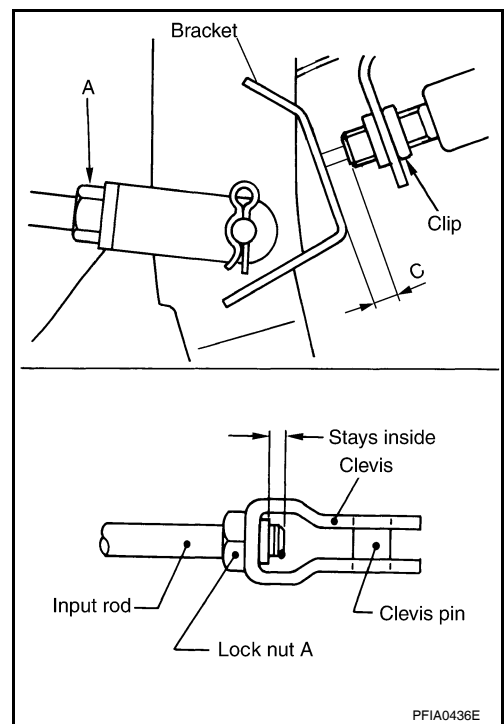

A
B
C
D
E
BR
G
H
I
J
K
L
M
N
O
P

BRAKE FLUID

< ON-VEHICLE MAINTENANCE >

BRAKE FLUID

Inspection

INFOID:000000005462742

LEVEL CHECK

- Make sure that a brake fluid level in reservoir tank is between MAX and MIN lines as shown.
- Visually check around reservoir tank for fluid leakage.
- If the level is excessively low, check brake system for leaks.
- If brake warning lamp remains illuminated after parking brake pedal is released, check brake system for fluid leaks.

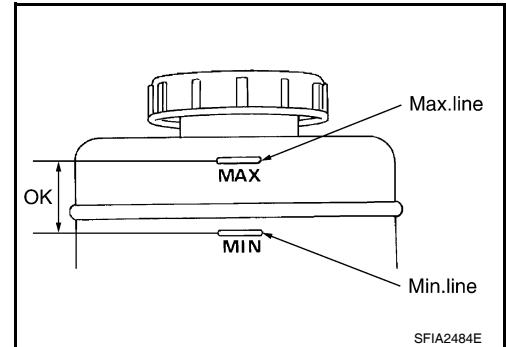

Drain and Refill

INFOID:000000005462743

CAUTION:

- Refill with new brake fluid. Refer to [MA-18, "FOR NORTH AMERICA : Fluids and Lubricants"](#) (for North America) or [MA-19, "FOR MEXICO : Fluids and Lubricants"](#) (for Mexico).
- Do not reuse drained brake fluid.
- Do not let brake fluid splash on the painted surfaces of the body. This might damage the paint. If brake fluid is splashed on painted areas, wash it away with water immediately.
- Before working, disconnect ABS actuator and electric unit (control unit) connector or battery negative terminal.

1. Turn ignition switch OFF and disconnect ABS actuator and electric unit (control unit) connector or battery negative terminal.
2. Connect a vinyl tube to bleed valve.
3. Depress brake pedal, loosen bleed valve, and gradually remove brake fluid.

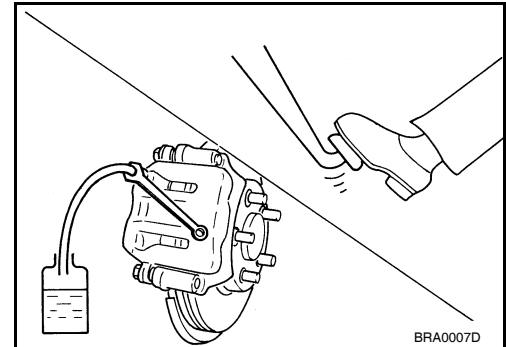

4. Make sure there is no foreign material in the reservoir tank, and refill with new brake fluid.
5. Rest foot on brake pedal. Loosen bleed valve. Slowly depress brake pedal until it stops. Tighten bleed valve. Release brake pedal. Repeat the process a few times, then pause to add new brake fluid to master cylinder. Continue until the new brake fluid flows out of bleed valve. Bleed the air out of the brake hydraulic system. Refer to [BR-16, "Bleeding Brake System"](#).

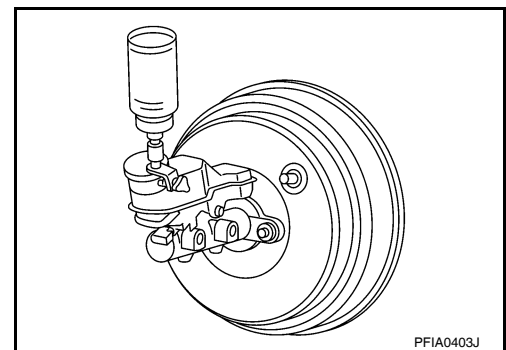

Bleeding Brake System

INFOID:000000005462744

BLEEDING BRAKE SYSTEM

CAUTION:

- While bleeding, pay attention to master cylinder fluid level.

BRAKE FLUID

< ON-VEHICLE MAINTENANCE >

- **Before working, disconnect ABS actuator and electric unit (control unit) connectors or battery negative terminal.**
- 1. Turn ignition switch OFF and disconnect ABS actuator and electric unit (control unit) connector or battery negative terminal.
- 2. Connect a vinyl tube to rear right brake caliper bleed valve.
- 3. Fully depress brake pedal 4 or 5 times.
- 4. With brake pedal depressed, loosen bleed valve to bleed air in brake line, and then tighten it immediately.
- 5. Repeat steps 3 and 4 until all of the air is out of the brake line.
- 6. Tighten the bleed valve to the specified torque. Refer to [BR-32. "Exploded View of Brake Caliper"](#) (front disc brake), [BR-36. "Exploded View of Brake Caliper"](#) (rear brake).
- 7. Repeat steps 2 through 6, with master cylinder reservoir tank filled at least halfway, bleed the air in order from the front left, rear left, front right bleed valves.

A
B
C
D
E
G
H
I
J
K
L
M
N
O
P

BR

BRAKE PEDAL

< ON-VEHICLE REPAIR >

ON-VEHICLE REPAIR

BRAKE PEDAL

Exploded View

INFOID:000000005462745

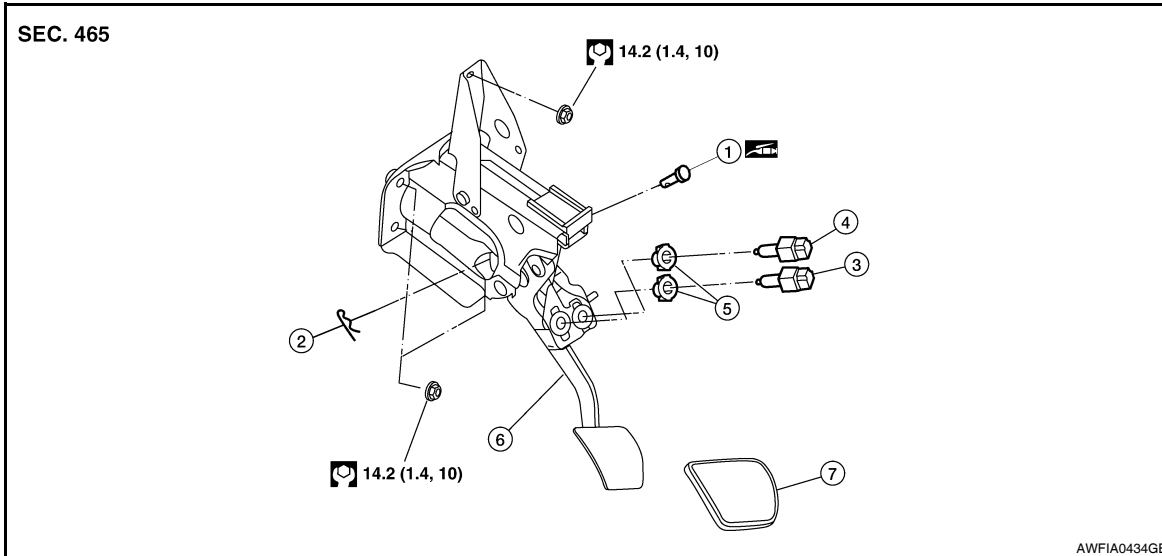

- | | | |
|---------------------|-------------|-------------------------|
| 1. Clevis pin | 2. Snap pin | 3. ASCD switch |
| 4. Stop lamp switch | 5. Clip | 6. Brake pedal assembly |
| 7. Brake pedal pad | | |

NOTE:

The clevis pin must be installed from the RH side as shown.

Removal and Installation

INFOID:000000005462746

REMOVAL

1. Remove instrument lower cover (LH) and lower knee protector. Refer to [IP-11, "Exploded View"](#).
2. Remove the accelerator pedal assembly. Refer to [ACC-4, "Removal and Installation"](#).
3. Disconnect stop lamp switch and ASCD switch connector.
4. Remove stop lamp switch and ASCD switch from brake pedal assembly.
5. Remove snap pin and clevis pin from brake booster clevis.
6. Disconnect the steering column upper joint and reposition it out of the way.
7. Remove brake pedal assembly to brake booster nuts. Pull brake booster toward engine room to the extent that does not deform the brake tubes.

WARNING:

Do not bend the brake tubing.

8. Remove brake booster clevis from input rod.
9. Remove top nut and then remove brake pedal assembly.
 - Temporarily install the brake pedal assembly to brake booster nuts by hand to support the brake booster.

CAUTION:

Avoid damage from dropping the brake pedal assembly during handling.

INSPECTION AFTER REMOVAL

Check the brake assembly for the following items:

- Crack or deformation of the clevis pin.
- Crack of any welded portion of the brake pedal assembly.
- Brake pedal bend or deformation.

BRAKE PEDAL

< ON-VEHICLE REPAIR >

INSTALLATION

Installation is in the reverse order of removal.

- Check the brake pedal for smooth operation. There should be no binding or sticking when applying or releasing the brake pedal.
- Adjust brake pedal height after installing brake pedal assembly. Refer to [BR-14, "Inspection and Adjustment"](#).

A
B
C
D
E
BR
G
H
I
J
K
L
M
N
O
P

BRAKE TUBE AND HOSE

< ON-VEHICLE REPAIR >

BRAKE TUBE AND HOSE

Hydraulic Circuit

INFOID:000000005462747

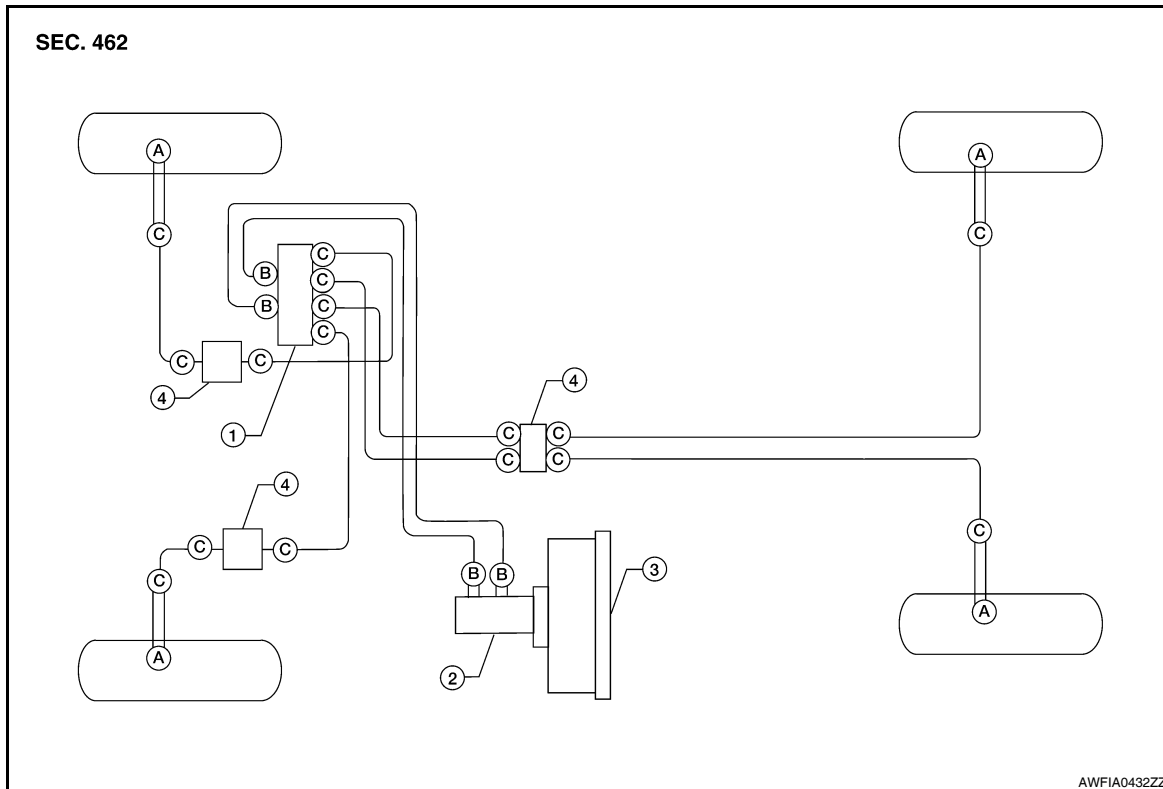

- | | | |
|---|--|---|
| 1. Actuator | 2. Master cylinder | 3. Brake booster |
| 4. Connector | A. Union bolt
18.2 N·m (1.9 kg-m, 13 ft-lb) | B. Flare nut M12
18.2 N·m (1.9 kg-m, 13 ft-lb) |
| C. Flare nut M10
16.2 N·m (1.7 kg-m, 12 ft-lb) | | |

CAUTION:

- All hoses and piping (tubes) must be free from excessive bending, twisting and pulling.
- Make sure there is no interference with other parts when turning the steering wheel both clockwise and counterclockwise.
- The brake piping is an important safety part. If a brake fluid leak is detected, always disassemble the parts. Replace applicable part with a new one, if necessary.
- Be careful not to splash brake fluid on painted areas; it may cause paint damage. If brake fluid is splashed on painted areas, wash it away with water immediately.
- Do not bend or twist brake hose sharply, or strongly pull it.
- When removing components, cover connections so that no dirt, dust, or other foreign matter gets in.
- Refill with new specified brake fluid. Refer to [MA-18, "FOR NORTH AMERICA : Fluids and Lubricants"](#) (for North America or [MA-18, "FOR NORTH AMERICA : Fluids and Lubricants"](#) (for Mexico).
- Do not reuse drained brake fluid.

Removal and Installation of Front Brake Piping and Brake Hose

INFOID:000000005462748

REMOVAL

1. Remove the front wheel and tire. Refer to [WT-63, "Adjustment"](#).
2. Drain brake fluid. Refer to [BR-16, "Drain and Refill"](#).

BRAKE TUBE AND HOSE

< ON-VEHICLE REPAIR >

3. Disconnect brake hose from brake tube, using a suitable tool.
4. Remove lock plate and then remove brake hose from bracket.

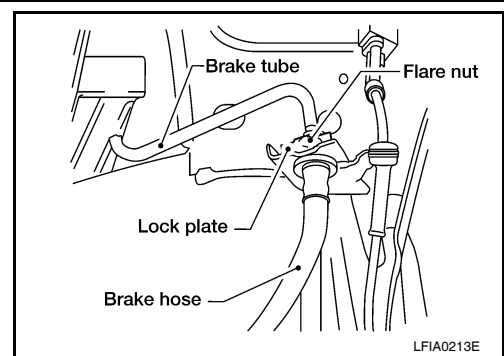

5. Remove union bolt (A) and then remove brake hose from brake caliper assembly.

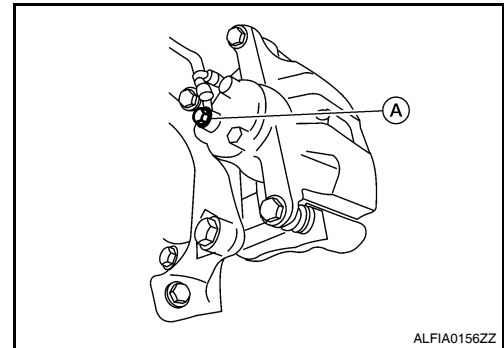

INSTALLATION

1. Install the front wheel and tire. Refer to [WT-63, "Adjustment"](#).
2. Install brake hose by aligning with the protrusion on brake caliper assembly, then install the union bolt and new copper washers and tighten union bolt to specification. Refer to [BR-20, "Hydraulic Circuit"](#).

CAUTION:

Do not reuse copper washers.

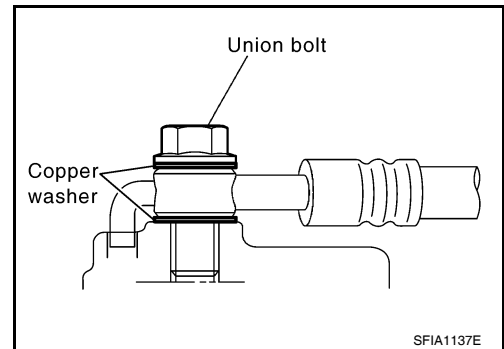

3. Connect brake hose to brake tube, partially tighten flare nut by hand as much as possible, then secure it to the bracket with lock plate.
4. Tighten flare nut to the specified torque, using a suitable tool. Refer to [BR-20, "Hydraulic Circuit"](#).

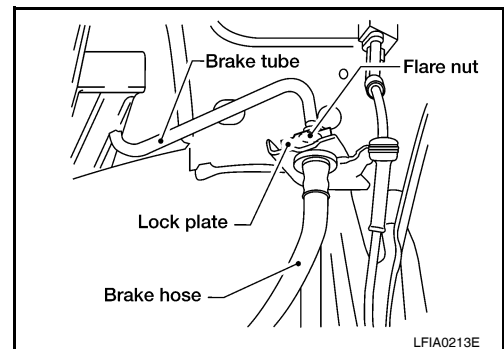

5. Refill brake fluid and bleed air. Refer to [BR-16, "Bleeding Brake System"](#).

Removal and Installation of Rear Brake Piping and Brake Hose

INFOID:000000005462749

REMOVAL

1. Remove the rear wheel and tire. Refer to [WT-63, "Adjustment"](#).
2. Drain brake fluid. Refer to [BR-16, "Drain and Refill"](#).

BRAKE TUBE AND HOSE

< ON-VEHICLE REPAIR >

3. Disconnect brake hose from brake tube, using a suitable tool.
4. Remove lock plate and then remove brake hose from bracket.

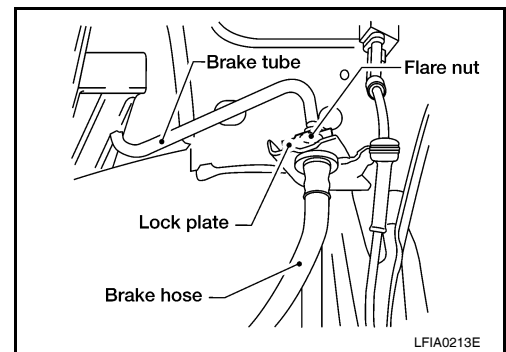

5. Remove union bolt (A), and then remove brake hose from brake caliper assembly.

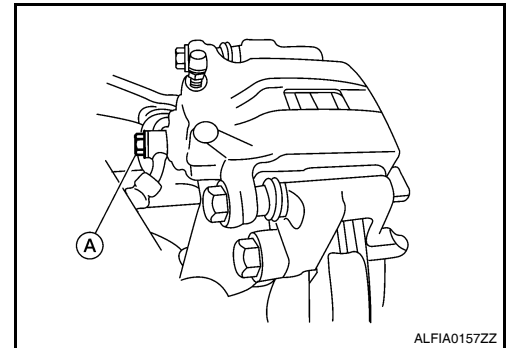

INSTALLATION

1. Install the rear wheel and tire. Refer to [WT-63, "Adjustment"](#).
2. Install brake hose by aligning with the protrusion on brake caliper assembly, then install the union bolt and new copper washers and tighten union bolt to specification. Refer to [BR-20, "Hydraulic Circuit"](#).

CAUTION:

Do not reuse copper washers.

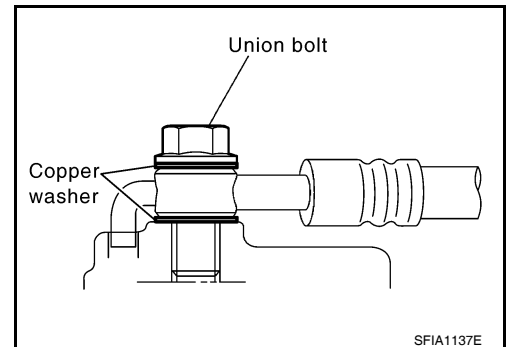

3. Connect brake hose to brake tube, partially tighten flare nut by hand as much as possible, then secure it to the bracket with lock plate.
4. Tighten flare nut to the specified torque, using a suitable tool. Refer to [BR-20, "Hydraulic Circuit"](#).

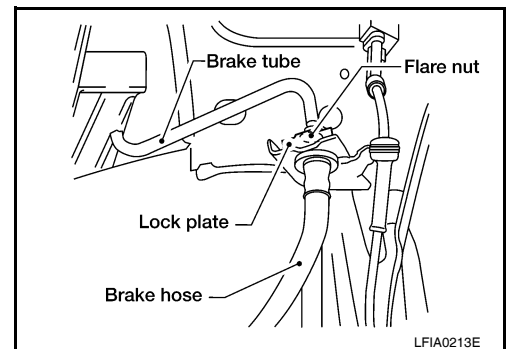

5. Refill brake fluid and bleed air. Refer to [BR-16, "Bleeding Brake System"](#).

Inspection After Installation

INFOID:000000005462750

CAUTION:

Brake tubes and hoses are important safety parts. Always disassemble the parts and retighten their fittings if a brake fluid leak is detected. Replace applicable part with a new one, if a damaged part is detected.

BRAKE TUBE AND HOSE

< ON-VEHICLE REPAIR >

1. Check brake lines (tubes and hoses), and connections for fluid leaks, damage, twist, deformation, contact with other parts, and loose connections. Replace any parts as necessary. Refer to [BR-20, "Hydraulic Circuit"](#).
2. While depressing brake pedal under a force of 785 N (80 kg-f, 177 lb-f) with engine running for approximately 5 seconds, check each part for fluid leaks.

A

B

C

D

E

BR

G

H

I

J

K

L

M

N

O

P

BRAKE MASTER CYLINDER

< ON-VEHICLE REPAIR >

BRAKE MASTER CYLINDER

Exploded View

INFOID:000000005462751

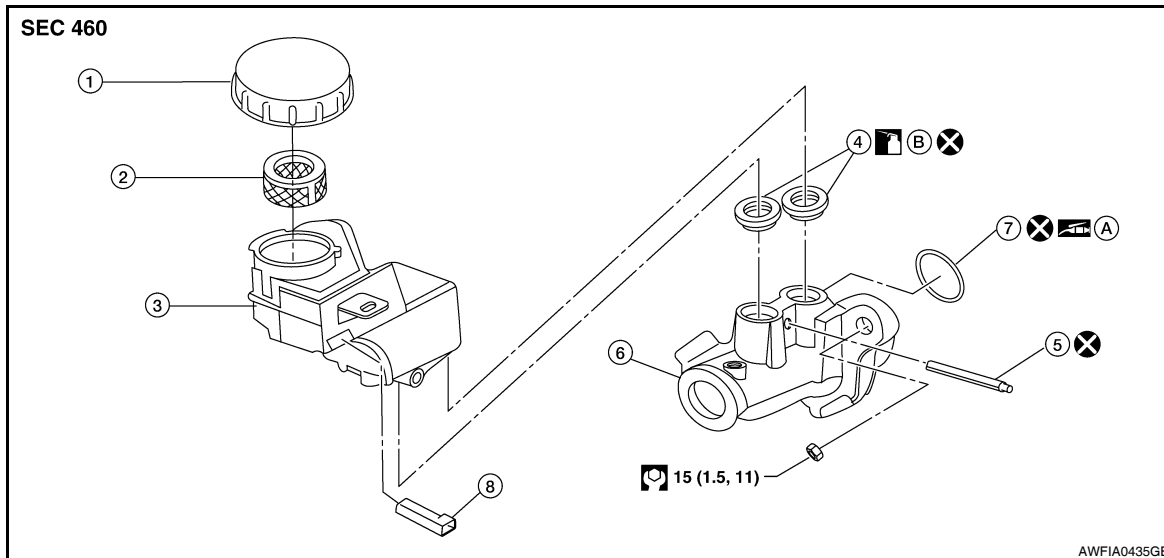

- | | | |
|------------------|---------------------------------------|--|
| 1. Reservoir cap | 2. Oil strainer | 3. Reservoir tank |
| 4. Grommet | 5. Pin | 6. Master cylinder assembly |
| 7. O-ring | 8. Brake fluid level switch connector | A. PBC (Poly Butyl Cuprysil) grease or silicone-based grease |
| B. Brake fluid | | |

Removal and Installation

INFOID:000000005462752

CAUTION:

- Do not splash brake fluid on painted areas; it may cause paint damage. If brake fluid is splashed on painted areas, wash it away with water immediately.
- Never scratch the master cylinder piston when installing/removing because the piston is exposed. Check if any dust is on the piston, and wash with brake fluid if needed.
- Hold cylinder body when handling master cylinder. Never pull by holding the piston because the piston might become detached.
- Refill with new brake fluid.
- Never reuse drained brake fluid.

REMOVAL

1. Remove the engine room cover.
2. Remove the air cleaner assembly. Refer to [EM-23, "Removal and Installation"](#).
3. Drain brake fluid. Refer to [BR-16, "Drain and Refill"](#).
4. Disconnect brake fluid level switch harness connector.
5. Disconnect master cylinder brake tubes, using a suitable tool.
6. Remove master cylinder nuts and remove master cylinder assembly.

INSTALLATION

Installation is in the reverse order of removal.

- Tighten brake tube flare nut to the specified torque using a suitable tool. Refer to [BR-20, "Hydraulic Circuit"](#).
- Refill with new brake fluid and bleed air. Refer to [BR-16, "Bleeding Brake System"](#).

CAUTION:

BRAKE MASTER CYLINDER

< ON-VEHICLE REPAIR >

Apply silicone grease to brake booster at position (A) as shown, be sure the O-ring is in proper position when installing master cylinder to brake booster.

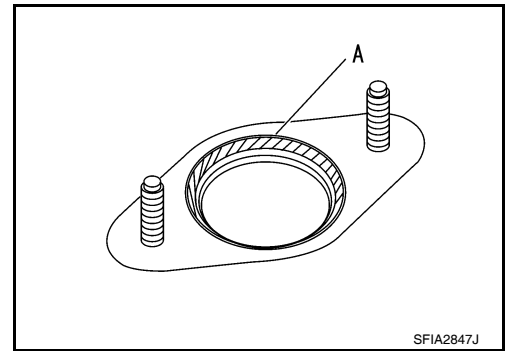

A
B
C
D
E

BR

G
H
I
J
K
L
M
N
O
P

BRAKE BOOSTER

< ON-VEHICLE REPAIR >

BRAKE BOOSTER

Exploded View

INFOID:000000005462753

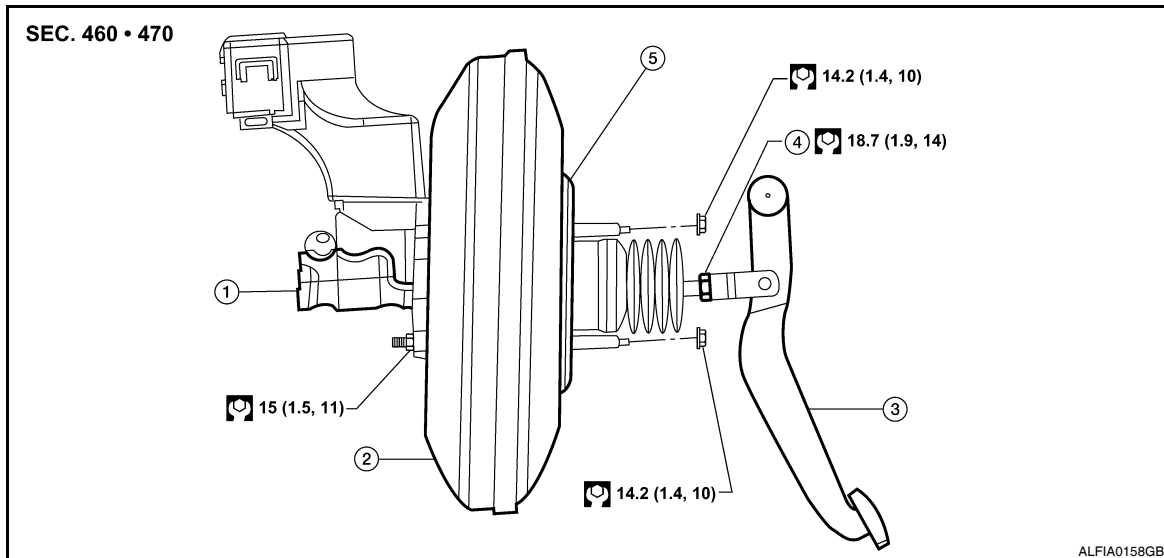

- | | | |
|-----------------------------|------------------|----------------|
| 1. Master cylinder assembly | 2. Brake booster | 3. Brake pedal |
| 4. Lock nut | 5. Gasket | |

Removal and installation

INFOID:000000005462754

REMOVAL

1. Release the fuel pressure. Refer to [EC-576, "Inspection"](#).
2. Disconnect the battery negative terminal.
3. Drain the brake fluid. Refer to [BR-16, "Drain and Refill"](#).
4. Remove the engine room cover.
5. Remove the air cleaner assembly. Refer to [EM-23, "Removal and Installation"](#).
6. Remove cowl top and cowl top extension LH. Refer to [EXT-18, "Removal and Installation"](#).
7. Disconnect fuel line and reposition out of the way.
8. Disconnect the brake lines and brake fluid level switch connector.
9. Remove master cylinder from booster assembly. Refer to [BR-24, "Removal and Installation"](#).
10. Disconnect vacuum hose from brake booster.
11. Remove instrument panel lower cover LH. Refer to [IP-11, "Exploded View"](#).
12. Disconnect the accelerator pedal connector.
13. Remove snap pin and clevis pin from inside vehicle.
14. Disconnect the steering column upper joint and reposition it out of the way.
15. Remove nuts on brake booster and brake pedal assembly, then remove brake pedal. Refer to [BR-18, "Exploded View"](#).
16. Remove brake booster from dash panel on engine room side.

CAUTION:

Be careful not to deform or bend brake tube while removing brake booster.

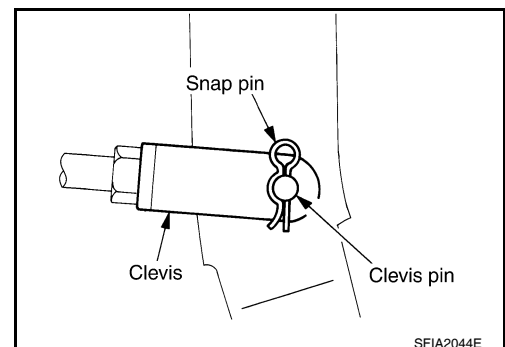

SFIA2044E

INSTALLATION

CAUTION:

- **Be careful not to deform or bend brake tube while installing brake booster.**

BRAKE BOOSTER

< ON-VEHICLE REPAIR >

- Replace clevis pin if it is damaged.
- Do not damage brake booster stud bolt threads. If brake booster is tilted during installation, the dash panel may damage the threads.

1. Loosen lock nut to adjust input rod length (B) to the specified value as shown.

Input rod length (B) : Refer to [BR-47, "Brake Booster"](#).

2. After adjusting input rod length (B), temporarily tighten the lock nut to install the booster assembly. At this time, make sure that a gasket between booster assembly and dash panel is installed.

CAUTION:

Always install gasket between brake booster and dash panel.

3. Install and connect brake pedal with clevis of input rod.
4. Install brake pedal bracket nuts and tighten them to the specified torque. Refer to [BR-18, "Exploded View"](#).
5. Connect the steering column upper joint.
6. Connect the accelerator pedal connector.
7. Install instrument panel lower cover LH. Refer to [IP-11, "Exploded View"](#).
8. Install vacuum hose into brake booster.
9. Install master cylinder to booster assembly. Refer to [BR-24, "Removal and Installation"](#).
10. Connect the brake lines and brake fluid level switch connector.
11. Connect fuel lines.
12. Install the air cleaner assembly. Refer to [EM-23, "Removal and Installation"](#).
13. Install the engine room cover.
14. Install cowl top and cowl top extension LH. Refer to [EXT-18, "Removal and Installation"](#).
15. Connect the battery negative terminal.
16. Adjust the brake pedal height and the play of the brake pedal. Refer to [BR-14, "Inspection and Adjustment"](#).
17. Tighten lock nut of input rod to the specified torque. Refer to [BR-26, "Exploded View"](#).
18. Refill new brake fluid and bleed air. Refer to [BR-16, "Bleeding Brake System"](#).

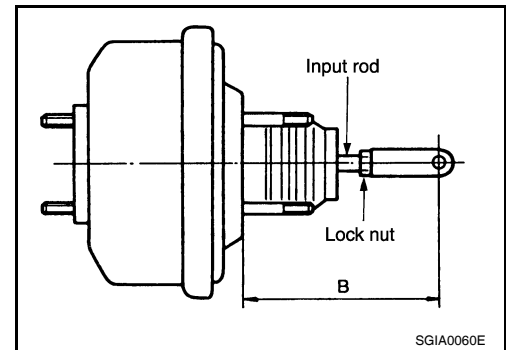

VACUUM LINES

< ON-VEHICLE REPAIR >

VACUUM LINES

Exploded View

INFOID:000000005462755

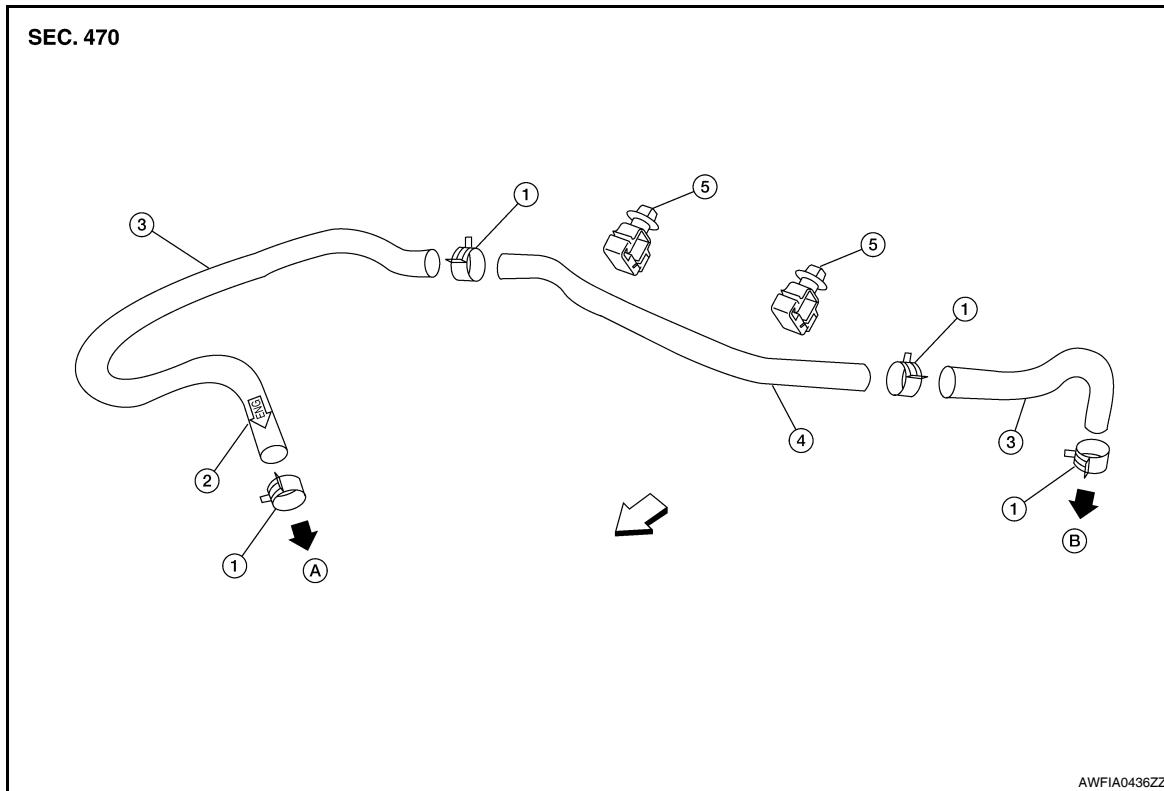

- | | | |
|---------------------|--------------------------------|-----------------------|
| 1. Clamp | 2. Check valve direction stamp | 3. Vacuum hose |
| 4. Vacuum pipe | 5. Clip | A. To intake manifold |
| B. To brake booster | ← Front | |

Removal and Installation

INFOID:000000005462756

REMOVAL

1. Disconnect the vacuum hose from the brake booster.
2. Disconnect the vacuum hose from the intake manifold.
3. Release the clips and remove the vacuum pipe with the vacuum hoses attached.
4. Remove the vacuum hoses from the vacuum pipe.

INSPECTION AFTER REMOVAL

Visual Inspection

Check for correct installation, damage and deterioration of the vacuum hoses and pipe.

Valve Air-tightness Check

- Connect a suitable tool (hand vacuum pump) at each end of the vacuum hose to inspect the check valve operation.

Vacuum applied at booster end : Refer to [BR-47, "Check Valve"](#).

Vacuum applied at intake manifold end : Refer to [BR-47, "Check Valve"](#).

- Replace the vacuum hose with check valve if out of specification.

INSTALLATION

Installation is in the reverse order of removal.

CAUTION:

VACUUM LINES

< ON-VEHICLE REPAIR >

- Because the vacuum hose contains a check valve, the vacuum hose must be installed in the correct position for proper operation. Refer to the stamp on the end of the vacuum hose to confirm correct installation. The brake booster will not operate normally if the vacuum hose with the check valve is installed in the wrong direction.
- Insert the vacuum pipe into the vacuum hose at least 24 mm (0.94 in) as shown.
- Do not use lubricating oil during installation.

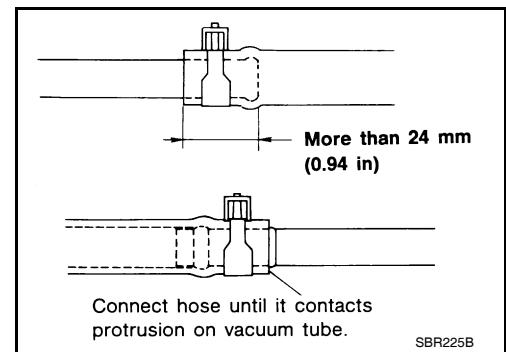

A

B

C

D

E

BR

G

H

I

J

K

L

M

N

O

P

FRONT DISC BRAKE

< ON-VEHICLE REPAIR >

FRONT DISC BRAKE

Exploded View of Brake Pads

INFOID:000000005713918

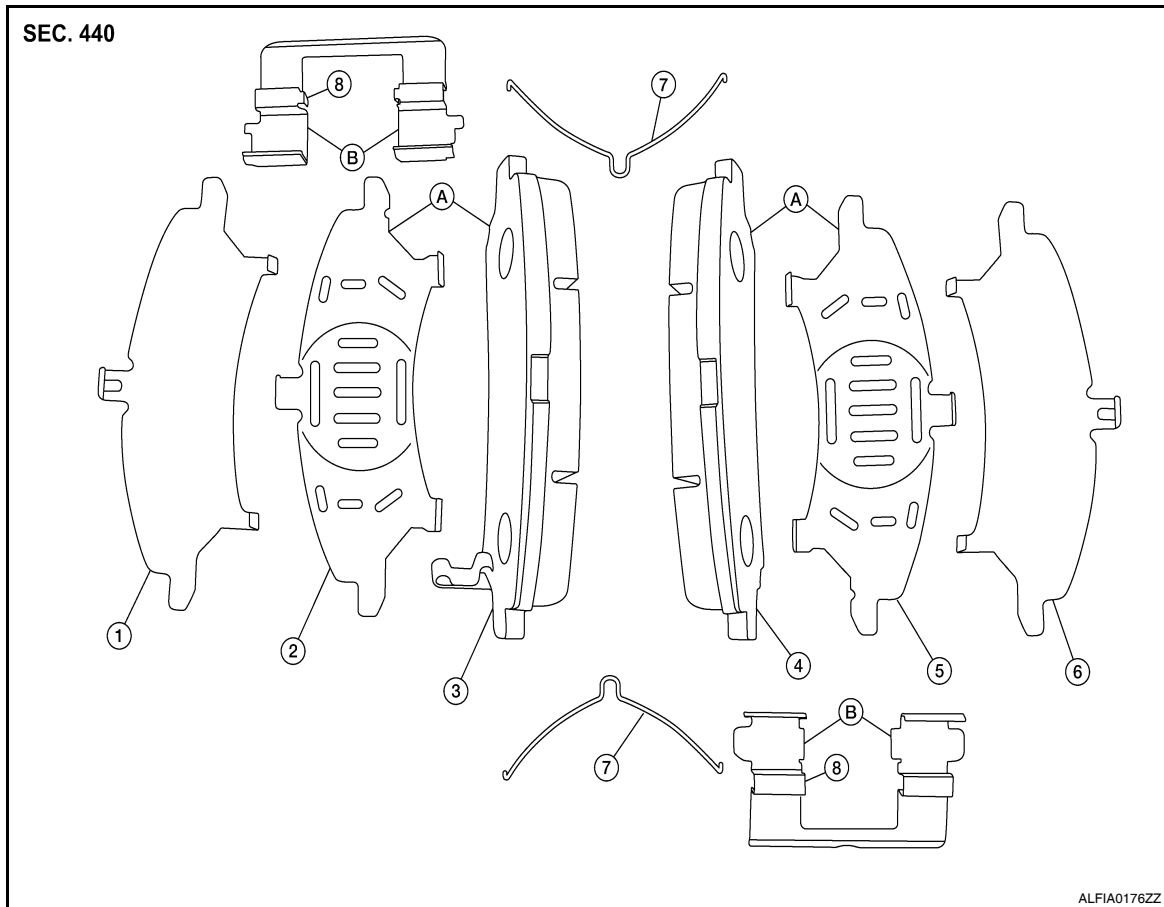

- | | | |
|-------------------------|------------------|----------------------------|
| 1. Inner shim cover | 2. Inner shim | 3. Inner pad |
| 4. Outer pad | 5. Outer shim | 6. Outer shim cover |
| 7. Anti-rattle clips | 8. Pad retainers | A. Molykote AS-880N grease |
| B. Molykote 7439 grease | | |

Removal and Installation of Brake Pads

INFOID:000000005713919

WARNING:

Clean dust on caliper and brake pad with a vacuum dust collector to minimize the hazard of air borne particles or other materials.

CAUTION:

- While removing brake pads, do not depress brake pedal because piston will pop out.
- It is not necessary to remove bolts on torque member and brake hose except for disassembly or replacement of caliper assembly. For brake pad removal, hang cylinder body with a wire so as not to stretch brake hose.
- Do not damage piston boot.
- If any shim is subject to serious corrosion, replace it with a new one.
- Always replace shim and shim cover as a set when replacing brake pads.
- Keep rotor free from brake fluid.
- Burnish the brake pads and disc rotor contacting surfaces, after refinishing or replacing rotors, after replacing pads, or if a soft pedal occurs at very low mileage. Refer to [BR-31, "Brake Burnishing Procedure"](#).

REMOVAL

1. Remove front wheel and tire.

FRONT DISC BRAKE

< ON-VEHICLE REPAIR >

- Partially drain brake fluid from master cylinder.
- Remove upper and lower sliding pin bolts (2) without disconnecting the union bolt (1).

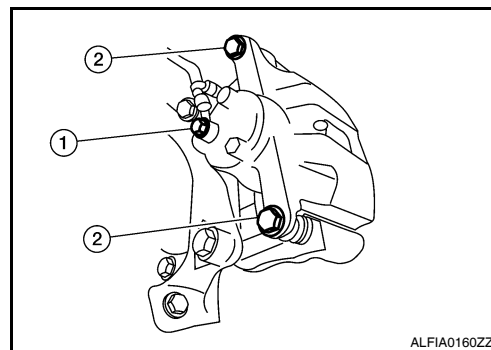

- Hang cylinder body with a wire, and do not twist or stretch the brake hose.
- Remove anti-rattle clips, pads, shims, and shim covers from torque member.

INSTALLATION

- Apply Molykote AS-880N grease or equivalent between the inner and outer shims and the back of the brake pads.
- Install the inner and outer shims and shim covers to the inner pad and outer pad.

CAUTION:

Do not get grease on the inner and outer pad friction surfaces.

- Apply Molykote 7439 grease to the pad retainer and attach the pad retainer to the torque member.
- Install the assembled inner and outer shims, shim covers, pads and anti-rattle clips to the torque member.

CAUTION:

Do not get grease on the inner and outer pad or rotor friction surfaces.

- Press piston into cylinder body using suitable tool, then install the cylinder body on the torque member.

CAUTION:

When replacing pads with new set, check the brake fluid level in the reservoir tank because brake fluid returns to the master cylinder reservoir tank when pressing in the piston.

- Install the upper and lower sliding pin bolts (2) and tighten it to the specified torque.
 - Union bolt (1)

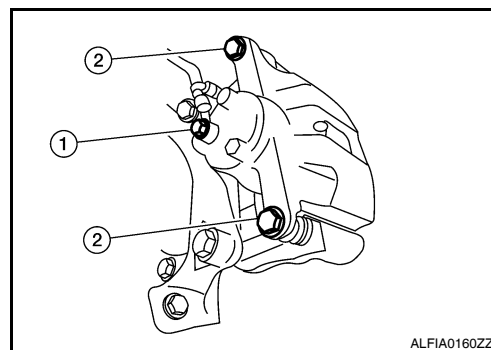
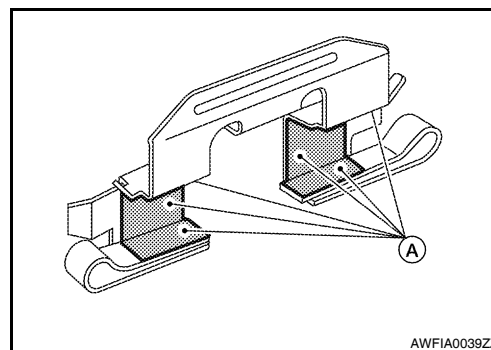

- Check front disc brakes for drag.
- Install the front wheel and tire. Refer to [WT-63. "Adjustment"](#).
- Check brake fluid level. Refer to [BR-16. "Inspection"](#).

Brake Burnishing Procedure

INFOID:000000005713920

Burnish contact surfaces between disc rotors and pads according to following procedure after refinishing or replacing rotors, after replacing pads, or if a soft pedal occurs at very low mileage.

CAUTION:

- **Be careful of vehicle speed because the brake does not operate easily until pad and disc rotor are securely fitted.**

FRONT DISC BRAKE

< ON-VEHICLE REPAIR >

• **Only perform this procedure under safe road and traffic conditions. Use extreme caution.**

1. Drive vehicle on straight, flat road.
2. Depress brake pedal with the power to stop vehicle within 3 to 5 seconds until the vehicle stops.
3. Drive without depressing brake for a few minutes to cool the brake.
4. Repeat steps 1 to 3 until pad and disc rotor are securely fitted.

Exploded View of Brake Caliper

INFOID:000000005713921

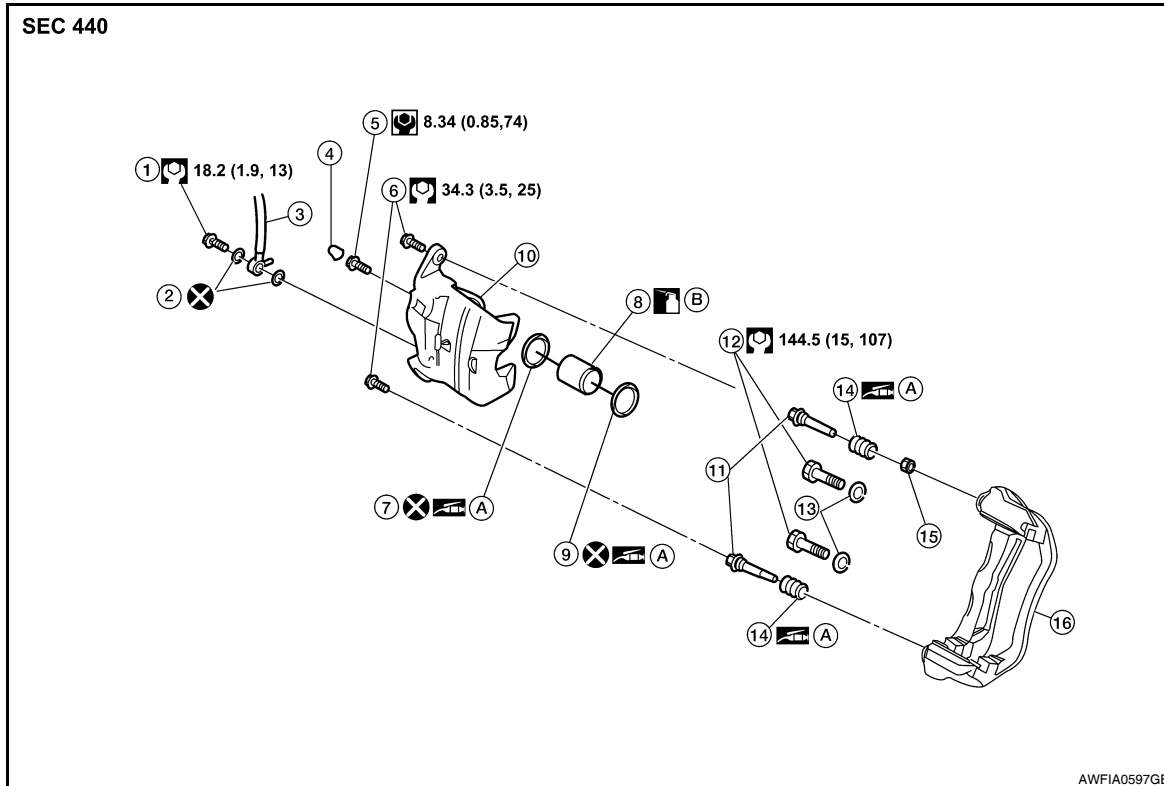

- | | | |
|-------------------|----------------------|------------------------|
| 1. Union bolt | 2. Copper washer | 3. Brake hose |
| 4. Cap | 5. Bleed valve | 6. Sliding pin bolt |
| 7. Piston seal | 8. Piston | 9. Piston boot |
| 10. Cylinder body | 11. Sliding pin | 12. Torque member bolt |
| 13. Washer | 14. Sliding pin boot | 15. Bushing |
| 16. Torque member | A. Rubber grease | B. Brake fluid |

Removal and Installation of Brake Caliper and Rotor

INFOID:000000005713922

WARNING:

Clean dust on caliper and brake pad with a vacuum dust collector to minimize the hazard of air borne particles or other materials.

CAUTION:

- When removing and installing the cylinder body, do not depress the brake pedal because the piston will pop out.
- Do not damage the piston boot.
- Keep the brake rotor free from grease and brake fluid.
- Refill the brake reservoir with new brake fluid only.
- Never reuse the drained brake fluid.

REMOVAL

1. Remove front wheel and tire.
2. Secure the disc rotor using a wheel nut.
3. Drain the brake fluid. Refer to [BR-16. "Drain and Refill"](#).

FRONT DISC BRAKE

< ON-VEHICLE REPAIR >

4. Remove the union bolt (1) and then disconnect the brake hose from the caliper assembly. Discard the copper washers.

CAUTION:

Do not reuse the copper washers.

5. Remove the torque member bolts (2), and remove the brake caliper assembly.

CAUTION:

Do not drop the brake pads.

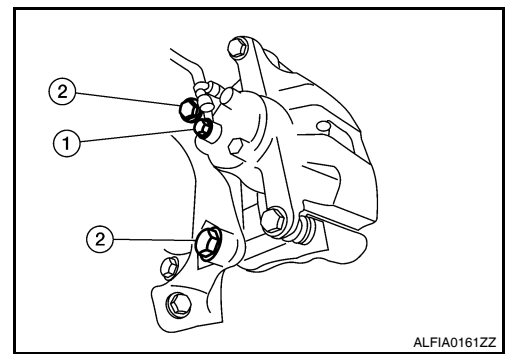

6. Remove the disc rotor. If reusing the disc rotor, apply a matching mark as shown for installation.

CAUTION:

Put matching marks on wheel hub assembly and disc rotor, if reusing the disc rotor.

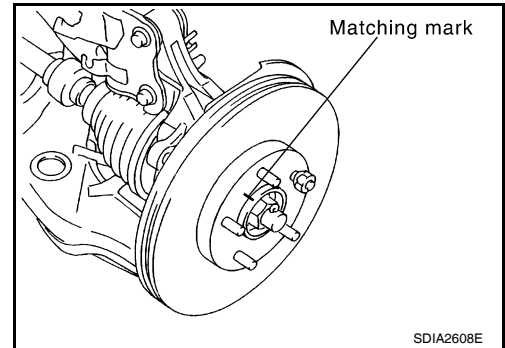

INSTALLATION

1. Install the disc rotor. If reusing the disc rotor, align the matching mark on the disc rotor and wheel hub assembly for installation as shown.

CAUTION:

Align the matching marks on wheel hub assembly and disc rotor, if reusing the disc rotor.

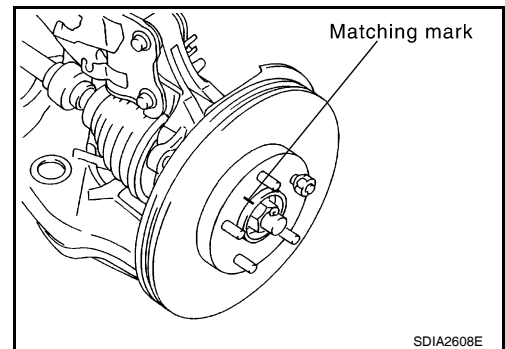

2. Install the brake caliper assembly, and tighten the torque member bolts to the specified torque.

CAUTION:

Do not allow oil or any moisture on all contact surfaces between steering knuckle and caliper assembly, bolts, and washer.

3. Install the brake hose with two new copper washers, using the L-shaped pin for alignment as shown, then tighten the union bolt to the specified torque.

CAUTION:

Do not reuse the copper washers.

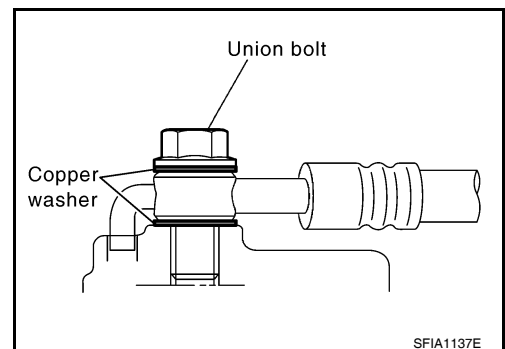

4. Refill the brake hydraulic system with new brake fluid and bleed out the air. Refer to [BR-16. "Bleeding Brake System"](#).
5. Check the front disc brakes for drag.
6. Install the front wheel and tire. Refer to [WT-63. "Adjustment"](#).

A
B
C
D
E
BR
G
H
I
J
K
L
M
N
O
P

REAR DISC BRAKE

< ON-VEHICLE REPAIR >

REAR DISC BRAKE

Exploded View of Brake Pads

INFOID:000000005713923

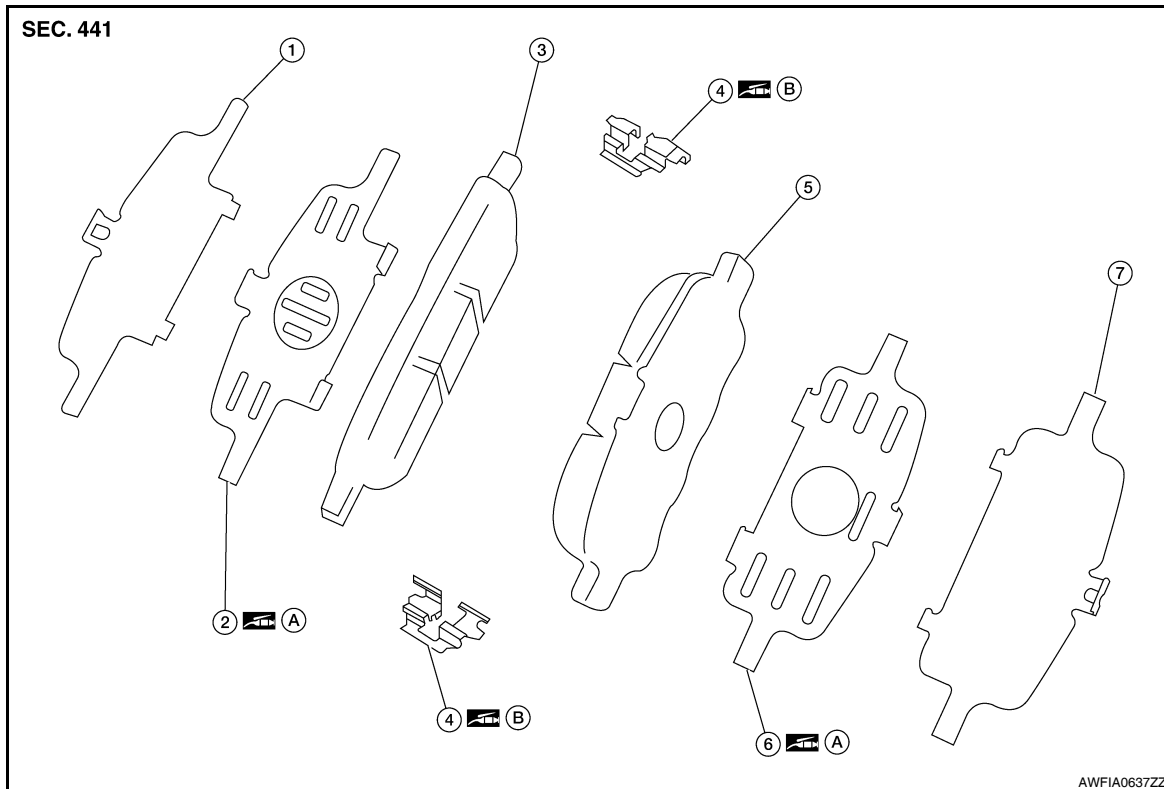

- | | | |
|---------------------|----------------------------|-------------------------|
| 1. Inner shim cover | 2. Inner shim | 3. Inner pad |
| 4. Pad retainer | 5. Outer pad | 6. Outer shim |
| 7. Outer shim cover | A. Molykote AS-880N grease | B. Molykote 7439 grease |

Removal and Installation of Brake Pads

INFOID:000000005713924

WARNING:

Clean dust on caliper and brake pad with a vacuum dust collector to minimize the hazard of air borne particles or other materials.

CAUTION:

- While removing and installing cylinder body, do not depress brake pedal because piston will pop out.
- It is not necessary to remove bolts on torque member and brake hose except for disassembly or replacement of caliper assembly. For pad removal and installation, hang cylinder body with a wire so as not to stretch brake hose.
- Do not damage piston boot.
- If any shim is subject to serious corrosion, replace it with a new one.
- Always replace shim and shim covers as a set when replacing brake pads.
- Keep rotor free from brake fluid.
- Burnish the brake pads and disc rotor mutually contacting surfaces after refinishing or replacing rotors, after replacing pads, or if a soft pedal occurs at very low mileage. Refer to [BR-31, "Brake Burnishing Procedure"](#).

REMOVAL

1. Remove the rear wheel and tire.
2. Partially drain brake fluid from master cylinder.
3. Remove the upper sliding pin bolt and loosen the lower sliding pin bolt to swing the cylinder body down.
4. Remove the pads, pad retainers, shims, and shim covers from the torque member.

REAR DISC BRAKE

< ON-VEHICLE REPAIR >

CAUTION:

Do not deform the pad retainers when removing them from the torque member.

INSTALLATION

1. Apply Molykote AS-880N grease or equivalent to between shim covers and shims. Install inner shim, inner shim cover to inner pad. Install outer shim and outer shim cover to outer pad.
2. Apply Molykote 7439 grease or equivalent to between pad retainer and pad. Install pad retainers and pads to torque member.
3. Press in piston using suitable tool, until the pads can be installed, and then install the cylinder body in the torque member.

CAUTION:

In the case of replacing a pad with new one, check the brake fluid level in the reservoir tank because brake fluid returns to the master cylinder reservoir tank when pressing in the piston.

4. Install upper sliding pin bolt and tighten the upper and lower sliding pin bolts to the specified torque.
5. Check the rear disc brakes for drag.
6. Install the rear wheel and tire. Refer to [WT-63, "Adjustment"](#).
7. Check brake fluid level. Refer to [BR-16, "Inspection"](#).

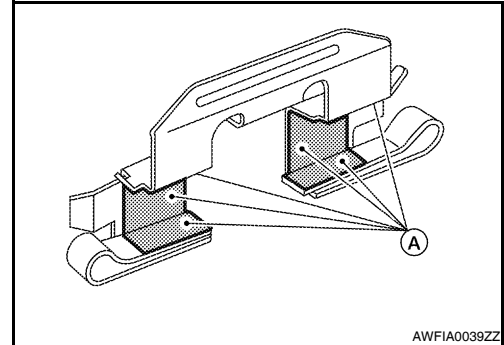

Brake Burnishing Procedure

INFOID:000000005713925

Burnish contact surfaces between disc rotors and pads according to following procedure after refinishing or replacing rotors, after replacing pads, or if a soft pedal occurs at very low mileage.

CAUTION:

- Be careful of vehicle speed because the brake does not operate easily until pad and disc rotor are securely fitted.
 - Only perform this procedure under safe road and traffic conditions. Use extreme caution.
1. Drive vehicle on straight, flat road.
 2. Depress brake pedal with the power to stop vehicle within 3 to 5 seconds until the vehicle stops.
 3. Drive without depressing brake for a few minutes to cool the brake.
 4. Repeat steps 1 to 3 until pad and disc rotor are securely fitted.

REAR DISC BRAKE

< ON-VEHICLE REPAIR >

Exploded View of Brake Caliper

INFOID:000000005713926

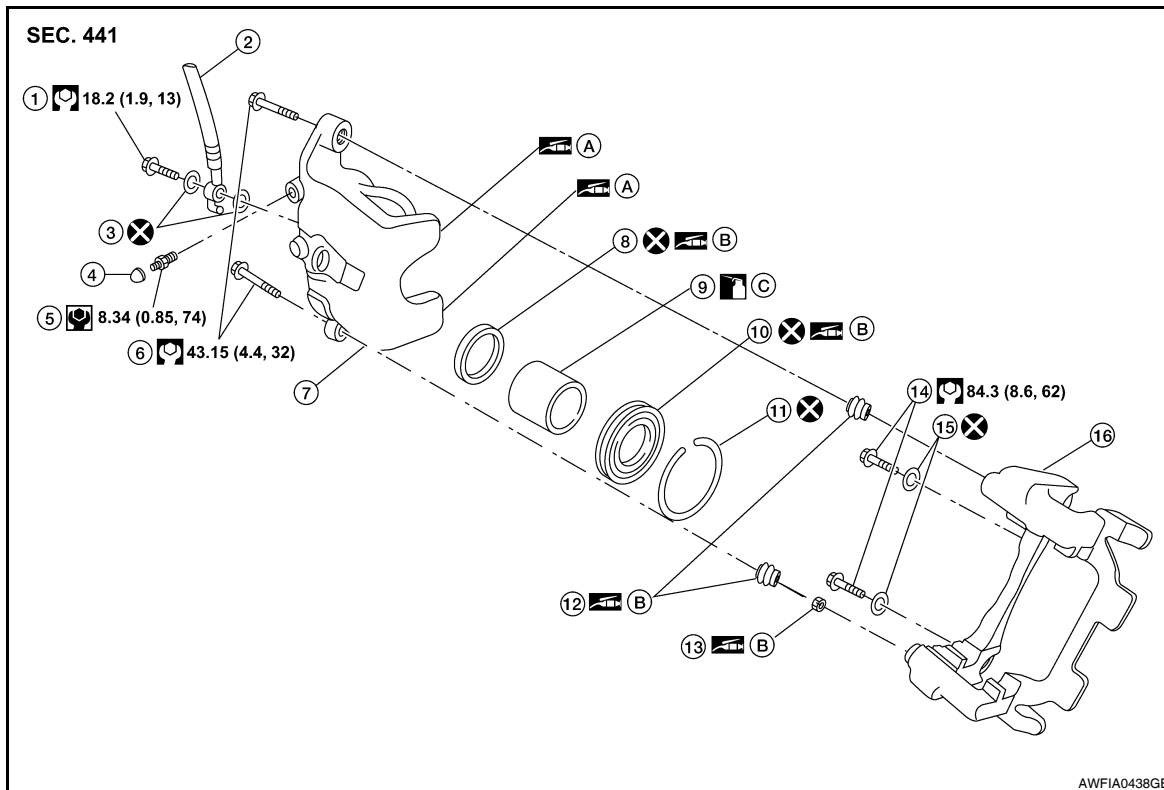

- | | | |
|-------------------|-------------------------|----------------------|
| 1. Union bolt | 2. Brake hose | 3. Copper washer |
| 4. Cap | 5. Bleed valve | 6. Sliding pin bolt |
| 7. Cylinder body | 8. Piston seal | 9. Piston |
| 10. Piston boot | 11. Retaining ring | 12. Sliding pin boot |
| 13. Bushing | 14. Torque member bolt | 15. Washer |
| 16. Torque member | A. Molykote M-77 grease | B. Rubber grease |
| C. Brake fluid | | |

Removal and Installation of Brake Caliper and Rotor

INFOID:000000005713927

WARNING:

Clean dust on caliper and brake pad with a vacuum dust collector to minimize the hazard of air borne particles or other materials.

CAUTION:

- While removing and installing the cylinder body, do not depress the brake pedal because the piston will pop out.
- Do not damage the piston boot.
- Keep rotor free from grease and brake fluid.
- Refill the brake reservoir with new brake fluid.
- Never reuse drained brake fluid.

REMOVAL

1. Remove the rear wheel and tire.
2. Hold the disc rotor in place by installing a wheel nut.
3. Drain the brake fluid. Refer to [BR-16, "Drain and Refill"](#).

REAR DISC BRAKE

< ON-VEHICLE REPAIR >

4. Remove the union bolt and copper washers, discard the copper washers. Then disconnect the brake hose from the cylinder body.

CAUTION:

Do not reuse the copper washers.

5. Remove the torque member bolts, and remove the brake caliper assembly.

CAUTION:

Do not drop brake the pads.

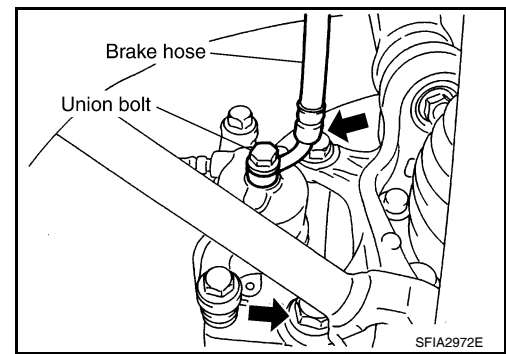

6. Remove the disc rotor. If reusing the disc rotor, before removing the disc rotor apply matching mark as shown.

CAUTION:

Put matching marks on wheel hub assembly and disc rotor, if reusing the disc rotor.

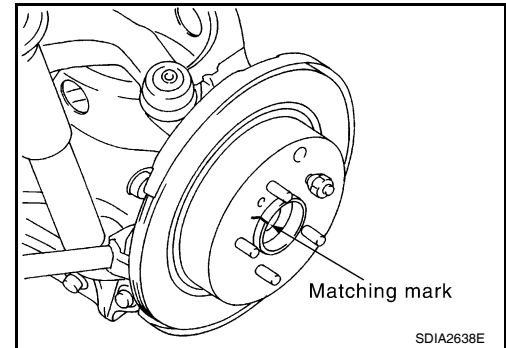

INSTALLATION

1. Install the disc rotor. If reusing the disc rotor, align the matching mark to position the disc rotor on the wheel hub assembly.

CAUTION:

Align the matching mark on wheel hub assembly and disc rotor, if reusing the disc rotor.

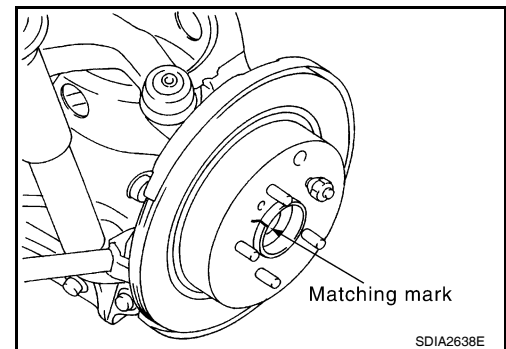

2. Install the brake caliper assembly, and tighten the torque member bolts to the specified torque.

CAUTION:

Before installing caliper assembly, wipe off oil and moisture on all mounting surfaces of rear axle and caliper assembly and threads, bolts and washers.

3. Install the brake hose with two new copper washers, using the L-shaped pin for alignment as shown, then tighten the union bolt to the specified torque.

CAUTION:

Do not reuse the copper washers.

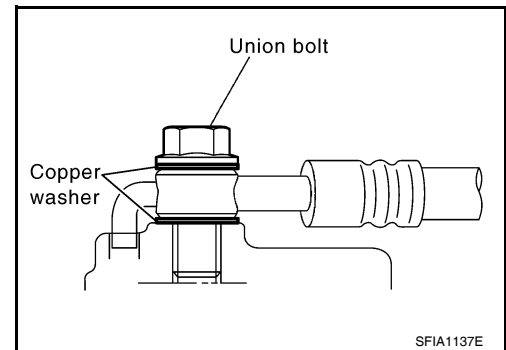

4. Refill the brake hydraulic system with new brake fluid and bleed out the air. Refer to [BR-16, "Bleeding Brake System"](#).
5. Check the rear disc brakes for drag.
6. Install the rear wheel and tire. Refer to [WT-63, "Adjustment"](#).

A
B
C
D
E
BR
G
H
I
J
K
L
M
N
O
P

BRAKE MASTER CYLINDER

< DISASSEMBLY AND ASSEMBLY >

DISASSEMBLY AND ASSEMBLY

BRAKE MASTER CYLINDER

Disassembly and Assembly

INFOID:000000005462767

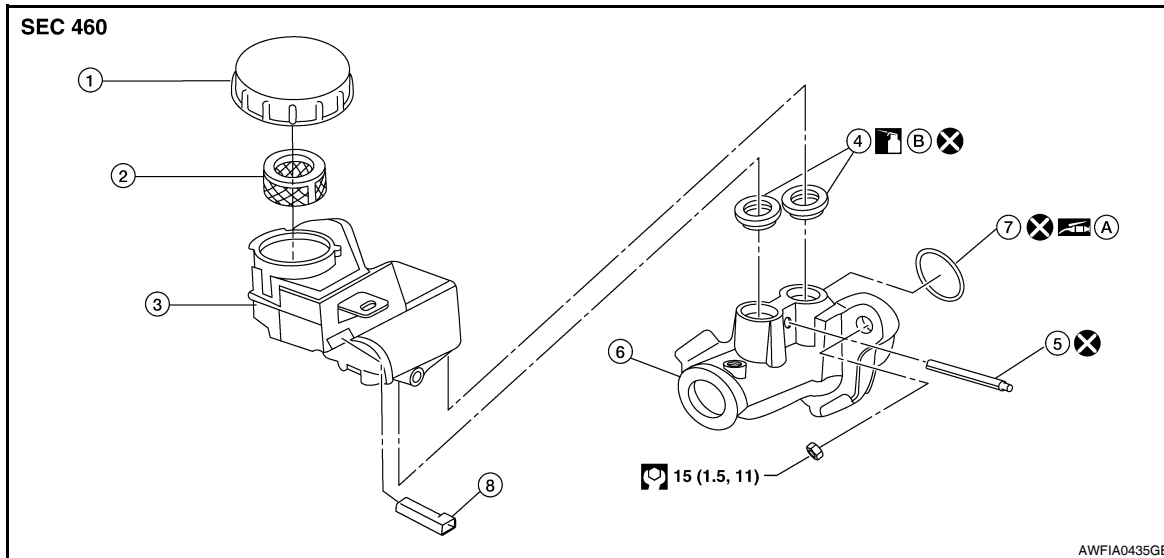

- | | | |
|------------------|---------------------------------------|--|
| 1. Reservoir cap | 2. Oil strainer | 3. Reservoir tank |
| 4. Grommet | 5. Pin | 6. Master cylinder assembly |
| 7. O-ring | 8. Brake fluid level switch connector | A. PBC (Poly Butyl Cuprysil) grease or silicone-based grease |
| B. Brake fluid | | |

DISASSEMBLY

CAUTION:

- While working, cover the primary piston rod with a cloth to prevent it from being damaged.
- Master cylinder assembly cannot be disassembled.
- Do not drop parts. If a part is dropped, do not use it.

1. Secure the flange of the cylinder body in a vise as shown.

CAUTION:

- Use copper plates or a cloth to cover the flange before securing it in a vise.
- When securing the master cylinder assembly in a vise, be sure not to over-tighten the vise.

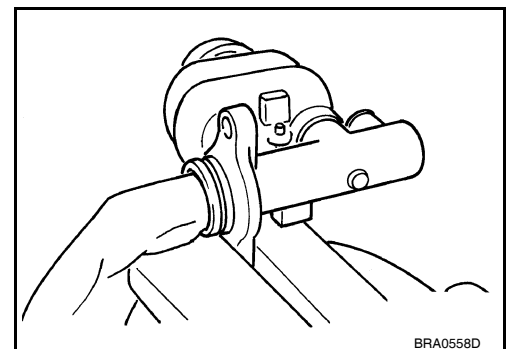

BRAKE MASTER CYLINDER

< DISASSEMBLY AND ASSEMBLY >

2. Remove the pin from reservoir tank, using suitable tool approximately 4 mm (0.16 in) diameter.
3. Remove the master cylinder assembly from the vise.
4. Remove the reservoir tank and grommets from the cylinder body and discard the grommets.

CAUTION:

Discard the grommets, do not reuse.

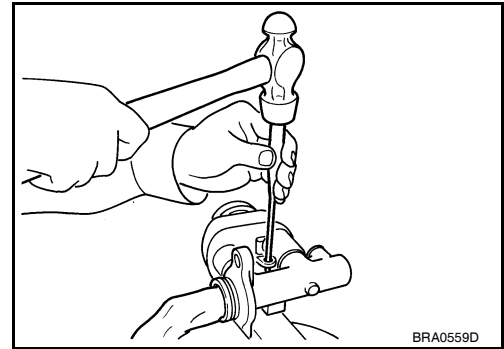

ASSEMBLY

Assembly is in the reverse order of disassembly.

CAUTION:

- While working, cover the primary piston rod with a cloth to prevent it from being damaged.
- Do not drop parts. If a part is dropped, do not use it.
- Never use mineral oil such as kerosene, or gasoline during the cleaning and assembly process.

A

B

C

D

E

BR

G

H

I

J

K

L

M

N

O

P

FRONT DISC BRAKE

< DISASSEMBLY AND ASSEMBLY >

FRONT DISC BRAKE

Disassembly and Assembly

INFOID:000000005713928

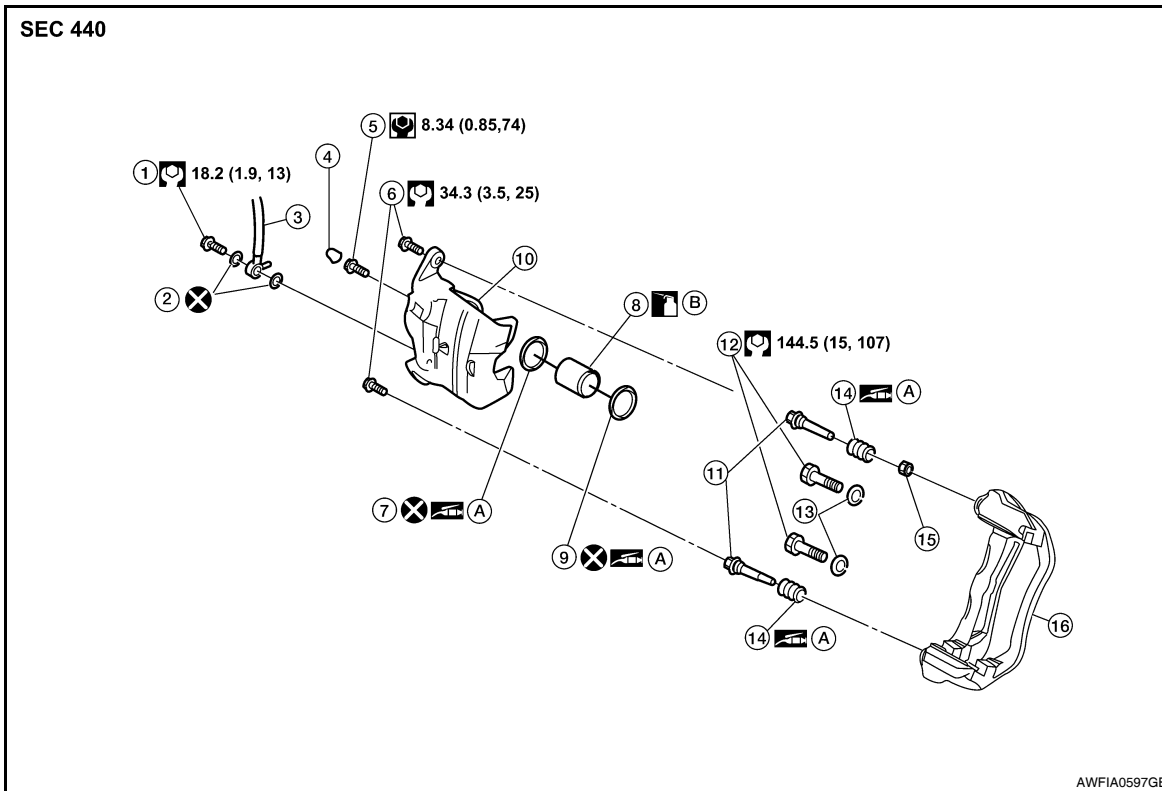

- | | | |
|-------------------|----------------------|------------------------|
| 1. Union bolt | 2. Copper washer | 3. Brake hose |
| 4. Cap | 5. Bleed valve | 6. Sliding pin bolt |
| 7. Piston seal | 8. Piston | 9. Piston boot |
| 10. Cylinder body | 11. Sliding pin | 12. Torque member bolt |
| 13. Washer | 14. Sliding pin boot | 15. Bushing |
| 16. Torque member | A. Rubber grease | B. Brake fluid |

NOTE:

Do not remove the torque member, pads, shims, shim covers, and anti-rattle clips when disassembling and assembling the cylinder body.

DISASSEMBLY

1. Remove the sliding pin bolts, and then remove the cylinder body from the torque member.

CAUTION:

Do not drop pads, shims, shim cover and anti-rattle clips from torque member.

2. Remove the sliding pins, bushing and sliding pin boots from the torque member.
3. Remove the cap and the bleed valve from the cylinder body.

FRONT DISC BRAKE

< DISASSEMBLY AND ASSEMBLY >

- Place a wooden block in the cylinder body and blow air through the union bolt hole to push out the piston and piston boot as shown. Discard the piston boot.

CAUTION:

- Do not get fingers caught between the piston and cylinder body.
- Do not reuse the piston boot.

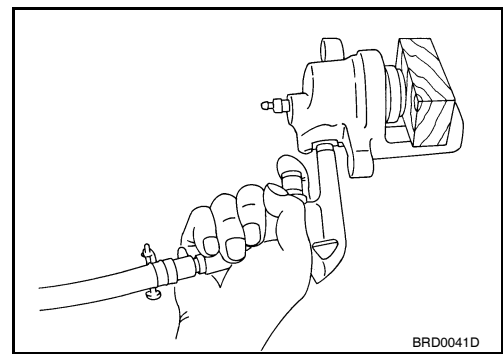

- Remove the piston seal from the cylinder body using a suitable tool as shown. Discard the piston seal.

CAUTION:

- Be careful not to damage the inner cylinder wall.
- Do not reuse the piston seal.

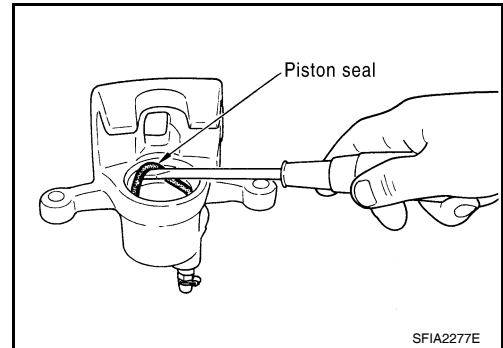

INSPECTION AFTER DISASSEMBLY

Cylinder Body

Check the inner cylinder wall for corrosion, wear, and damage. If a defect is detected, replace the cylinder body.

CAUTION:

Clean the cylinder body using new brake fluid. Never use mineral oils such as gasoline or kerosene.

Torque Member

Check the torque member for wear, cracks, and damage. If a defect is detected, replace the torque member.

Piston

Check the piston surface for corrosion, wear, and damage. If a defect is detected, replace the piston.

CAUTION:

The piston sliding surface is plated. Do not polish the piston with sandpaper.

Sliding Pin, Sliding Pin Bolt, and Sliding Pin Boot

Check the sliding pin, sliding pin bolt, and sliding pin boot for wear, damage, and cracks. If a defect is detected, replace the components as necessary.

ASSEMBLY

- Apply rubber grease to the new piston seal, and install it in the cylinder body.

CAUTION:

Do not reuse piston seal.

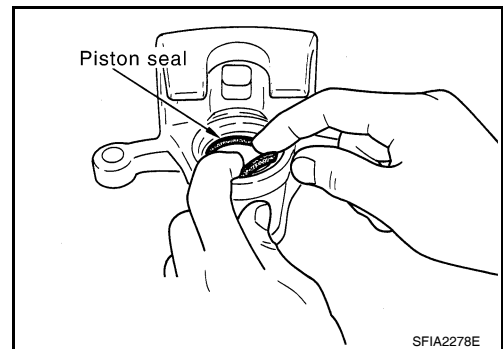

A
B
C
D
E
BR
G
H
I
J
K
L
M
N
O
P

FRONT DISC BRAKE

< DISASSEMBLY AND ASSEMBLY >

2. Apply rubber grease to new piston boot. Cover the piston end with the piston boot, and then install the cylinder side lip on the piston boot securely into a groove on the cylinder body.

CAUTION:

Do not reuse piston boot.

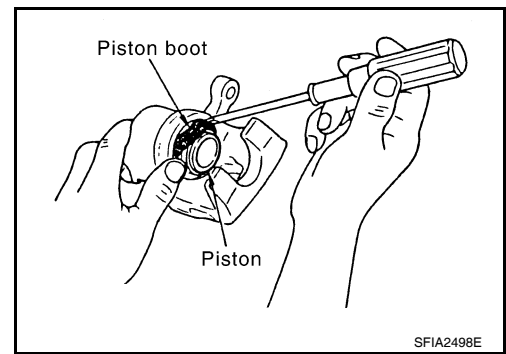

3. Apply brake fluid to the piston. Push the piston into the cylinder body by hand and push the piston boot piston-side lip into the piston groove.

CAUTION:

Press the piston evenly and vary the pressing point to prevent cylinder inner wall from being rubbed.

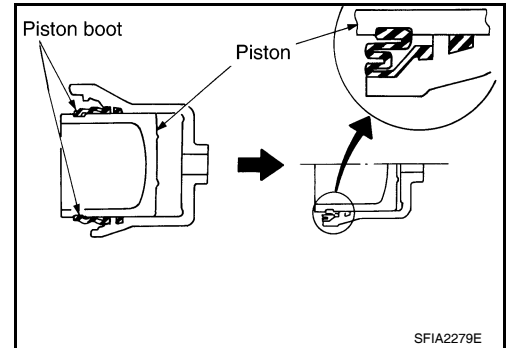

4. Install the bleed valve and cap to the cylinder body.
5. Install the sliding pins, bushing and sliding pin boots on the torque member.
6. Install the cylinder body to the torque member, and then tighten the sliding pin bolts to the specified torque.

REAR DISC BRAKE

< DISASSEMBLY AND ASSEMBLY >

REAR DISC BRAKE

Disassembly and Assembly

INFOID:000000005713929

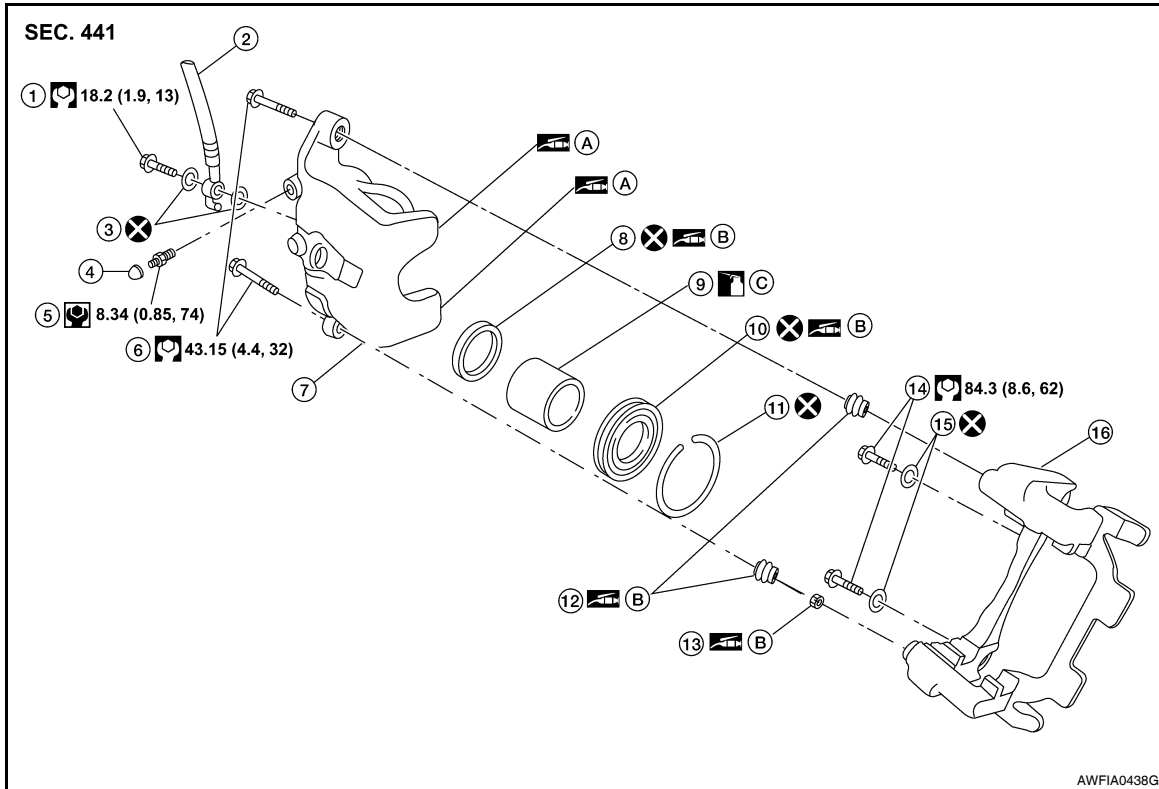

- | | | |
|-------------------|-------------------------|----------------------|
| 1. Union bolt | 2. Brake hose | 3. Copper washer |
| 4. Cap | 5. Bleed valve | 6. Sliding pin bolt |
| 7. Cylinder body | 8. Piston seal | 9. Piston |
| 10. Piston boot | 11. Retaining ring | 12. Sliding pin boot |
| 13. Bushing | 14. Torque member bolt | 15. Washer |
| 16. Torque member | A. Molykote M-77 grease | B. Rubber grease |
| C. Brake fluid | | |

NOTE:

Do not remove the torque member, pads, shims, shim covers, and pad retainers when disassembling and assembling the cylinder body.

DISASSEMBLY

1. Remove the sliding pin bolts, and then remove the cylinder body from the torque member.
CAUTION:
Do not drop pads, shims, shim cover and pad retainers from torque member.
2. Remove the sliding pin boots from the torque member.
3. Remove the cap and the bleed valve from the cylinder body.

REAR DISC BRAKE

< DISASSEMBLY AND ASSEMBLY >

4. Remove the retaining ring from the cylinder body using a suitable tool as shown. Discard the retaining ring.

CAUTION:

Do not reuse the retaining ring.

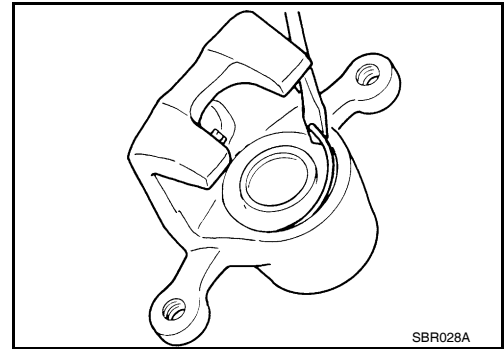

5. Place a wooden block in the cylinder body and blow air through the union bolt hole to push out the piston and piston boot as shown. Discard the piston boot.

CAUTION:

- Do not get fingers caught between the piston and cylinder body.
- Do not reuse the piston boot.

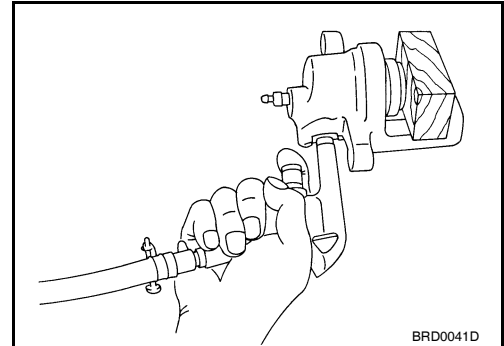

6. Remove the piston seal from the cylinder body using a suitable tool as shown. Discard the piston seal.

CAUTION:

- Be careful not to damage the inner cylinder wall.
- Do not reuse the piston seal.

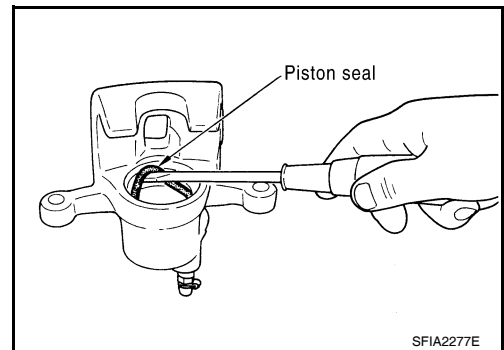

INSPECTION AFTER DISASSEMBLY

Cylinder Body

Check the inner cylinder wall for corrosion, wear, and damage. If a defect is detected, replace the cylinder body.

CAUTION:

Clean the cylinder body using new brake fluid. Never use mineral oils such as gasoline or kerosene.

Torque Member

Check the torque member for wear, cracks, and damage. If a defect is detected, replace the torque member.

Piston

Check the piston surface for corrosion, wear, and damage. If a defect is detected, replace the piston.

CAUTION:

The piston sliding surface is plated. Do not polish the piston with sandpaper.

Sliding Pin Bolt and Sliding Pin Boot

Check the sliding pin bolt and sliding pin boot for wear, damage, and cracks. If a defect is detected, replace the components as necessary.

ASSEMBLY

REAR DISC BRAKE

< DISASSEMBLY AND ASSEMBLY >

1. Apply rubber grease to the new piston seal, and install it in the cylinder body.

CAUTION:

Do not reuse piston seal.

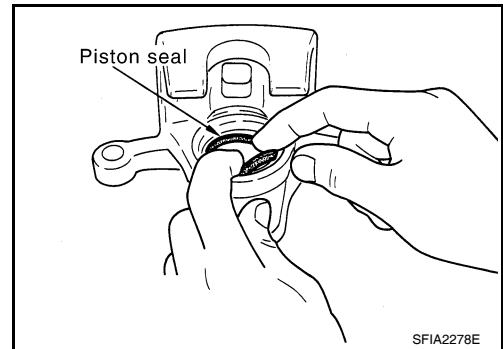

2. Apply rubber grease to the new piston boot. Cover the piston end with the piston boot, and then install the cylinder side lip on the piston boot securely into the groove on the cylinder body.

CAUTION:

Do not reuse piston boot.

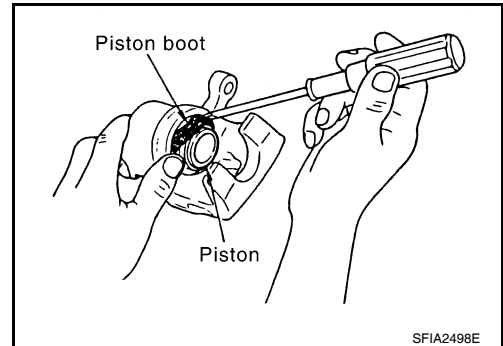

3. Apply brake fluid to the piston. Push the piston into the cylinder body by hand and push the piston boot piston-side lip into the piston groove.

CAUTION:

Press the piston evenly and vary the pressing point to prevent cylinder inner wall from being rubbed.

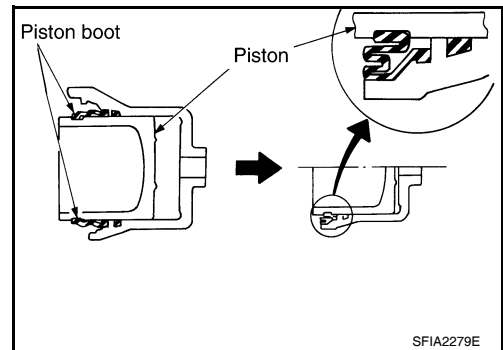

4. Secure piston boot with retaining ring.

CAUTION:

- **Make sure that boot is securely engaged in the groove on cylinder body.**
- **Do not reuse retainer ring.**

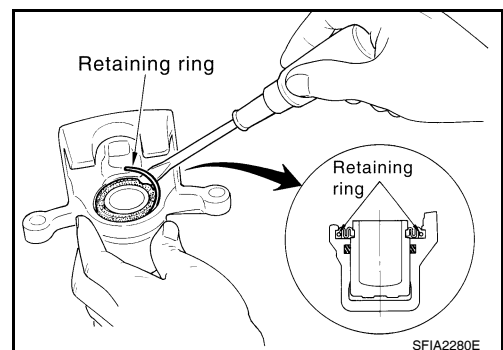

5. Install the bleed valve and cap to the cylinder body.
6. Install the sliding pin boots and bushing on the torque member.
7. Install the cylinder body to the torque member, and then tighten the sliding pin bolts to the specified torque.

SERVICE DATA AND SPECIFICATIONS (SDS)

< SERVICE DATA AND SPECIFICATIONS (SDS)

SERVICE DATA AND SPECIFICATIONS (SDS)

SERVICE DATA AND SPECIFICATIONS (SDS)

General Specifications

INFOID:000000005462770

Unit: mm (in)

Brake model		Kiriu	
Wheel size		457 (18)	483 (19)
Front brake	Cylinder bore diameter	57.15 (2.250)	
	Pad length × width × thickness	123.6 × 47.5 × 11 (4.866 × 1.870 × 0.433)	
	Rotor outer diameter × thickness	320 × 28 (12.598 × 1.102)	TBD
Rear brake	Brake model	Kiriu	
	Cylinder bore diameter	34.93 (1.375)	
	Pad length × width × thickness	83.0 × 33.0 × 8.5 (3.268 × 1.299 × 0.335)	
	Rotor outer diameter × thickness	308 × 16 (12.126 × 0.630)	
Master cylinder	Cylinder bore diameter	23.81 (0.937)	
Control valve	Valve model	Electric brake force distribution	
Brake booster	Booster model	Bosch	
Recommended brake fluid		DOT 3	

Brake Pedal

INFOID:000000005462771

Unit: mm (in)

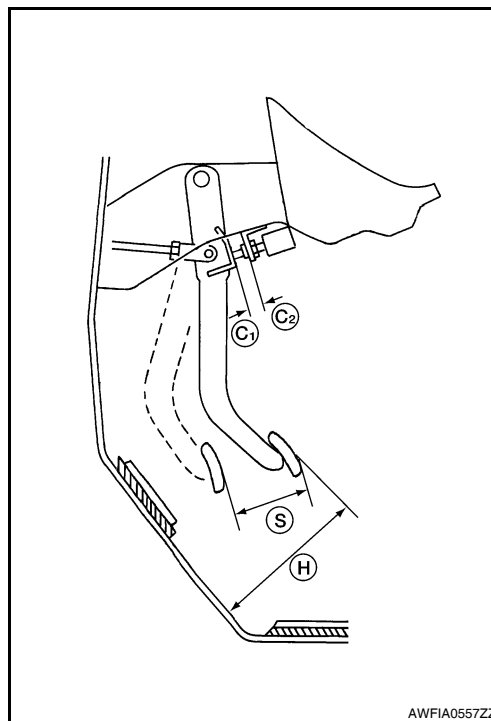

Brake pedal free height (H)	190.7 - 202.7 (7.51 - 7.98)
Brake pedal full stroke (S)	130.0 (5.12)
Clearance between brake pedal bracket and threaded end of stop lamp switch and ASCD cancel switch (C1) or (C2)	0.74 - 1.96 (0.0291 - 0.0772)

SERVICE DATA AND SPECIFICATIONS (SDS)

< SERVICE DATA AND SPECIFICATIONS (SDS)

Check Valve

INFOID:000000005462772

Vacuum leakage (booster hose end) [at vacuum of - 66.7 kPa (- 500 mmHg, - 19.69 inHg)]	1.3 kPa (10 mmHg, 0.39 inHg) maximum vacuum loss for 15 seconds
Vacuum leakage (intake manifold hose end)	No vacuum should exist.

Brake Booster

INFOID:000000005462773

Unit: mm (in)

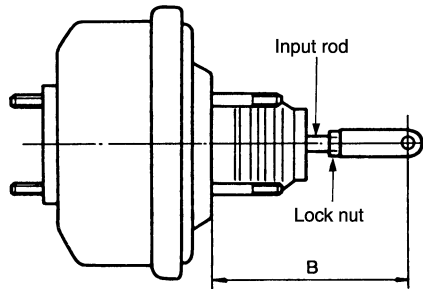

SGIA0060E

Input rod installation length (B)	125 ± 0.5 (4.92 ± 0.02)
-----------------------------------	-------------------------

Front Disc Brake

INFOID:000000005462774

Unit: mm (in)

Brake model		Kiriu	
Wheel size		457 (18)	483 (19)
Brake pad	Standard thickness (new)	11.0 (0.433)	
	Repair limit thickness	2.0 (0.079)	
Disc rotor	Standard thickness (new)	28.0 (1.102)	
	Repair limit thickness	26.0 (1.024)	
	Thickness variation (measured at 8 positions)	0.015 (0.0006)	
	Maximum runout (with it attached to the vehicle)	0.035 (0.0014)	

Rear Disc Brake

INFOID:000000005462775

Unit: mm (in)

Brake model		Kiriu	
Wheel size		457 (18)	483 (19)
Brake pad	Standard thickness (new)	8.5 (0.335)	
	Repair limit thickness	1.0 (0.039)	
Disc rotor	Standard thickness (new)	16.0 (0.630)	
	Repair limit thickness	14.0 (0.551)	
	Thickness variation (measured at 8 positions)	0.015 (0.0006)	
	Maximum runout (with it attached to the vehicle)	0.05 (0.002)	